

BioVendor

Research
and Diagnostic Products

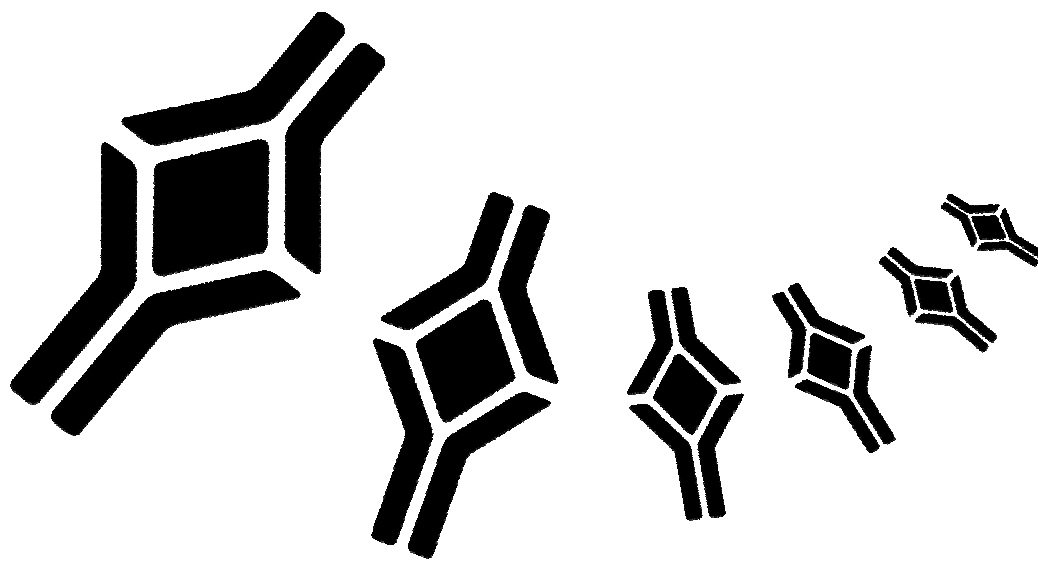

Human TIMP 1 ELISA

Product Data Sheet

Cat. No.: RBMS2018R

For Research Use Only

CONTENTS

1.	INTENDED USE	3
2.	SUMMARY	3
3.	PRINCIPLES OF THE TEST	5
4.	REAGENTS PROVIDED	7
5.	STORAGE INSTRUCTIONS – ELISA KIT	8
6.	SPECIMEN COLLECTION AND STORAGE INSTRUCTIONS	8
7.	MATERIALS REQUIRED BUT NOT PROVIDED	9
8.	PRECAUTIONS FOR USE	10
9.	PREPARATION OF REAGENTS	12
10.	TEST PROTOCOL	17
11.	CALCULATION OF RESULTS	22
12.	LIMITATIONS	25
13.	PERFORMANCE CHARACTERISTICS	26
14.	REFERENCES	31
15.	REAGENT PREPARATION SUMMARY	32
16.	TEST PROTOCOL SUMMARY	33

**»» This kit is manufactured by:
BioVendor – Laboratorní medicína, a.s.**

»» Use only the current version of Product Data Sheet enclosed with the kit!

1 INTENDED USE

The human TIMP-1 ELISA is an enzyme-linked immunosorbent assay for the quantitative detection of human tissue inhibitor of metalloproteinase-1 (TIMP-1). **The human TIMP-1 ELISA is for research use only. Not for diagnostic or therapeutic procedures.**

2 SUMMARY

The matrix metalloproteinases (MMPs) represent a family of more than 15 Zn-dependent endopeptidases with extracellular activity. They share a common conserved protease domain sequence in which three His residues form a complex with a catalytic Zn ion. Further, all MMPs contain a regulatory domain with a conserved motif.

The family of MMPs are capable of breaking down any extracellular matrix component. In normal physiology, MMPs produced by connective tissue are thought to contribute to tissue remodeling in development, in the menstrual cycle and in repair processes following tissue damage. In pathological situations mainly the involvement of breakdown of the connective tissues like in rheumatoid arthritis, cancer and periodontal and cardiovascular diseases are described. Leukocytes, mainly macrophages, are the major sources of MMP production which allow leukocytes to extravasate and penetrate tissues, which is a key event in inflammatory diseases. In parallel, metastatic cancer cells use MMPs to migrate to foreign tissue.

The tissue inhibitions of metalloproteinases (TIMPs) are naturally occurring proteins that specifically inhibit matrix metalloproteinases, thus maintaining balance between matrix destruction and formation. An imbalance between MMPs and the associated TIMPs may play a significant role in the invasive phenotype of malignant tumors.

TIMP-1 has been shown to inhibit tumor-induced angiogenesis. An imbalance of MMP/TIMP regulation has been implicated in several inflammatory diseases of the nervous system. In the pathogenesis of vascular diseases TIMP-1 seems to be down regulated.

3 PRINCIPLES OF THE TEST

An anti-human TIMP-1 coating antibody is adsorbed onto microwells.

Figure 1

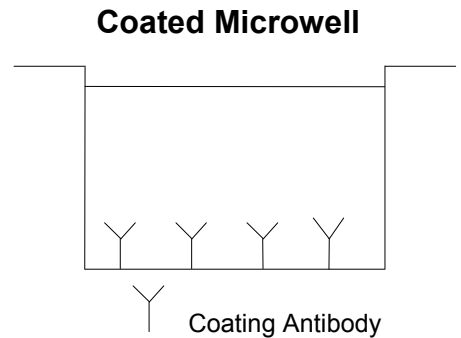

Human TIMP-1 present in the sample or standard binds to antibodies adsorbed to the microwells. A biotin-conjugated anti-human TIMP-1 antibody is added and binds to human TIMP-1 captured by the first antibody.

Figure 2

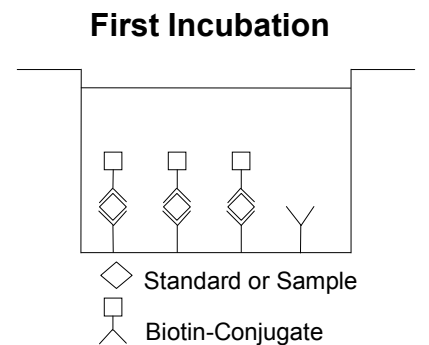

Following incubation unbound biotin-conjugated anti-human TIMP-1 antibody is removed during a wash step. Streptavidin-HRP is added and binds to the biotin-conjugated anti-human TIMP-1 antibody.

Figure 3

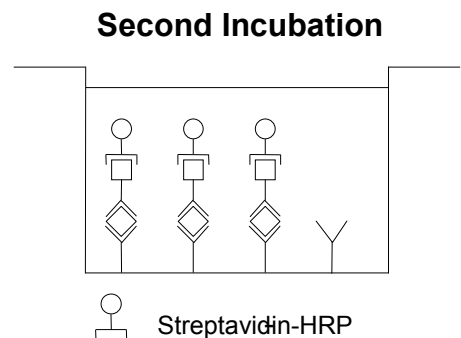

Following incubation unbound Streptavidin-HRP is removed during a wash step, and substrate solution reactive with HRP is added to the wells.

Figure 4

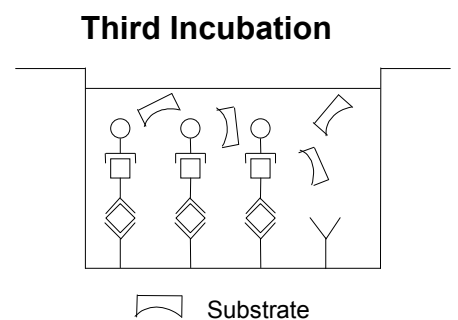

A coloured product is formed in proportion to the amount of human TIMP-1 present in the sample or standard. The reaction is terminated by addition of acid and absorbance is measured at 450 nm. A standard curve is prepared from 7 human TIMP-1 standard dilutions and human TIMP-1 sample concentration determined.

Figure 5

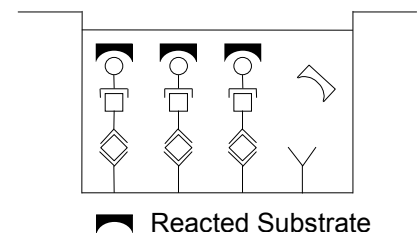

4 REAGENTS PROVIDED

- 1 aluminium pouch with a **Antibody Coated Microtiter Strips** with monoclonal antibody to human TIMP-1
- 1 vial (70 µl) **Biotin-Conjugate** anti-human TIMP-1 polyclonal antibody
- 1 vial (150 µl) **Streptavidin-HRP**
- 2 vials human TIMP-1 **Standard** lyophilized, 5000 pg/ml upon reconstitution
- 2 vials (5 ml) **Assay Buffer Concentrate 20x** (PBS with 1% Tween 20 and 10% BSA)
- 1 bottle (50 ml) **Wash Buffer Concentrate 20x** (PBS with 1% Tween 20)
- 1 vial (15 ml) **Substrate Solution** (tetramethyl-benzidine)
- 1 vial (12 ml) **Stop Solution** (1M Phosphoric acid)
- 1 vial (0.4 ml) **Blue-Dye**
- 1 vial (0.4 ml) **Green-Dye**
- 1 vial (0.4 ml) **Red-Dye**
- 4 **Adhesive Films**

5 STORAGE INSTRUCTIONS – ELISA KIT

Store kit reagents between 2° and 8°C. Immediately after use remaining reagents should be returned to cold storage (2° to 8°C). Expiry of the kit and reagents is stated on labels.

Expiry of the kit components can only be guaranteed if the components are stored properly, and if, in case of repeated use of one component, this reagent is not contaminated by the first handling.

6 SPECIMEN COLLECTION AND STORAGE INSTRUCTIONS

Cell culture supernatant, serum and plasma (EDTA, heparinized), were tested with this assay. Other biological samples might be suitable for use in the assay. Remove serum or plasma from the clot or cells as soon as possible after clotting and separation.

Pay attention to a possible “**Hook Effect**” due to high sample concentrations (see chapter 11).

Samples containing a visible precipitate must be clarified prior to use in the assay. Do not use grossly hemolyzed or lipemic specimens.

Samples should be aliquoted and must be stored frozen at -20°C to avoid loss of bioactive human TIMP-1. If samples are to be run within 24 hours, they may be stored at 2° to 8°C (for sample stability refer to 13.5).

Avoid repeated freeze-thaw cycles. Prior to assay, the frozen sample should be brought to room temperature slowly and mixed gently.

7 MATERIALS REQUIRED BUT NOT PROVIDED

- 5 ml and 10 ml graduated pipettes
- 5 μ l to 1000 μ l adjustable single channel micropipettes with disposable tips
- 50 μ l to 300 μ l adjustable multichannel micropipette with disposable tips
- Multichannel micropipette reservoir
- Beakers, flasks, cylinders necessary for preparation of reagents
- Device for delivery of wash solution (multichannel wash bottle or automatic wash system)
- Microwell strip reader capable of reading at 450 nm (620 nm as optional reference wave length)
- Glass-distilled or deionized water
- Statistical calculator with program to perform regression analysis

8 PRECAUTIONS FOR USE

- All chemicals should be considered as potentially hazardous. We therefore recommend that this product is handled only by those persons who have been trained in laboratory techniques and that it is used in accordance with the principles of good laboratory practice. Wear suitable protective clothing such as laboratory overalls, safety glasses and gloves. Care should be taken to avoid contact with skin or eyes. In the case of contact with skin or eyes wash immediately with water. See material safety data sheet(s) and/or safety statement(s) for specific advice.
- Reagents are intended for research use only and are not for use in diagnostic or therapeutic procedures.
- Do not mix or substitute reagents with those from other lots or other sources.
- Do not use kit reagents beyond expiration date on label.
- Do not expose kit reagents to strong light during storage or incubation.
- Do not pipette by mouth.
- Do not eat or smoke in areas where kit reagents or samples are handled.
- Avoid contact of skin or mucous membranes with kit reagents or specimens.
- Rubber or disposable latex gloves should be worn while handling kit reagents or specimens.
- Avoid contact of substrate solution with oxidizing agents and metal.
- Avoid splashing or generation of aerosols.
- In order to avoid microbial contamination or cross-contamination of reagents or specimens which may invalidate the test use disposable pipette tips and/or pipettes.

- Use clean, dedicated reagent trays for dispensing the conjugate and substrate reagent.
- Exposure to acid inactivates the conjugate.
- Glass-distilled water or deionized water must be used for reagent preparation.
- Substrate solution must be at room temperature prior to use.
- Decontaminate and dispose specimens and all potentially contaminated materials as they could contain infectious agents. The preferred method of decontamination is autoclaving for a minimum of 1 hour at 121.5°C.
- Liquid wastes not containing acid and neutralized waste may be mixed with sodium hypochlorite in volumes such that the final mixture contains 1.0% sodium hypochlorite. Allow 30 minutes for effective decontamination. Liquid waste containing acid must be neutralized prior to the addition of sodium hypochlorite.

9 PREPARATION OF REAGENTS

Buffer concentrates should be brought to room temperature and should be diluted before starting the test procedure.

9.1 Wash Buffer

If crystals have formed in the **Wash Buffer Concentrate (20x)**, warm it gently until they have completely dissolved.

Pour entire contents (50 ml) of the Wash Buffer Concentrate (20x) into a clean 1000 ml graduated cylinder. Bring to final volume of 1000 ml with glass-distilled or deionized water. Mix gently to avoid foaming. The pH of the final solution should adjust to 7.4.

Transfer to a clean wash bottle and store at 2° to 25°C. Please note that Wash Buffer is stable for 30 days.

Wash Buffer may also be prepared as needed according to the following table:

Number of Strips	Wash Buffer Concentrate (20x) (ml)	Distilled Water (ml)
1 - 6	25	475
1 - 12	50	950

9.2 Assay Buffer (1x)

Pour the entire contents (5 ml) of the **Assay Buffer Concentrate (20x)** into a clean 100 ml graduated cylinder. Bring to final volume of 100 ml with distilled water. Mix gently to avoid foaming.

Store at 2° to 8°C. Please note that the Assay Buffer (1x) is stable for 30 days.

Assay Buffer (1x) may also be prepared as needed according to the following table:

Number of Strips	Assay Buffer Concentrate (20x) (ml)	Distilled Water (ml)
1 - 6	2.5	47.5
1 - 12	5.0	95.0

9.3 Biotin-Conjugate

Please note that the Biotin-Conjugate should be used within 30 minutes after dilution.

Make a 1:100 dilution of the concentrated **Biotin-Conjugate** solution with Assay Buffer (1x) in a clean plastic tube as needed according to the following table:

Number of Strips	Biotin-Conjugate (ml)	Assay Buffer (1x) (ml)
1 - 6	0.03	2.97
1 - 12	0.06	5.94

9.4 Streptavidin-HRP

Please note that the Streptavidin-HRP should be used within 30 minutes after dilution.

Make a 1:100 dilution of the concentrated **Streptavidin-HRP** solution with Assay Buffer (1x) in a clean plastic tube as needed according to the following table:

Number of Strips	Streptavidin-HRP (ml)	Assay Buffer (1x) (ml)
1 - 6	0.06	5.94
1 - 12	0.12	11.88

9.5 Human TIMP-1 Standard

Reconstitute **human TIMP-1 standard** by addition of distilled water. Refer to the Certificate of Analysis for current volume of Distilled water needed for reconstitution of standard. Swirl or mix gently to insure complete and homogeneous solubilization (concentration of reconstituted standard = 5000 pg/ml). After usage remaining standard cannot be stored and has to be discarded.

Standard dilutions can be prepared directly on the microwell plate (see 10.d) or alternatively in tubes (see 9.5.1).

9.5.1 External Standard Dilution

Label 7 tubes, one for each standard point.

S1, S2, S3, S4, S5, S6, S7

Then prepare 1:2 serial dilutions for the standard curve as follows:

Pipette 225 μ l of Assay Buffer (1x) into each tube.

Pipette 225 μ l of reconstituted standard (concentration of standard = 5000 pg/ml) into the first tube, labelled S1, and mix (concentration of standard = 2500 pg/ml).
Pipette 225 μ l of this dilution into the second tube, labelled S2, and mix thoroughly before the next transfer.

Repeat serial dilutions 5 more times thus creating the points of the standard curve (see Figure 6).

Assay Buffer (1x) serves as blank.

Figure 6

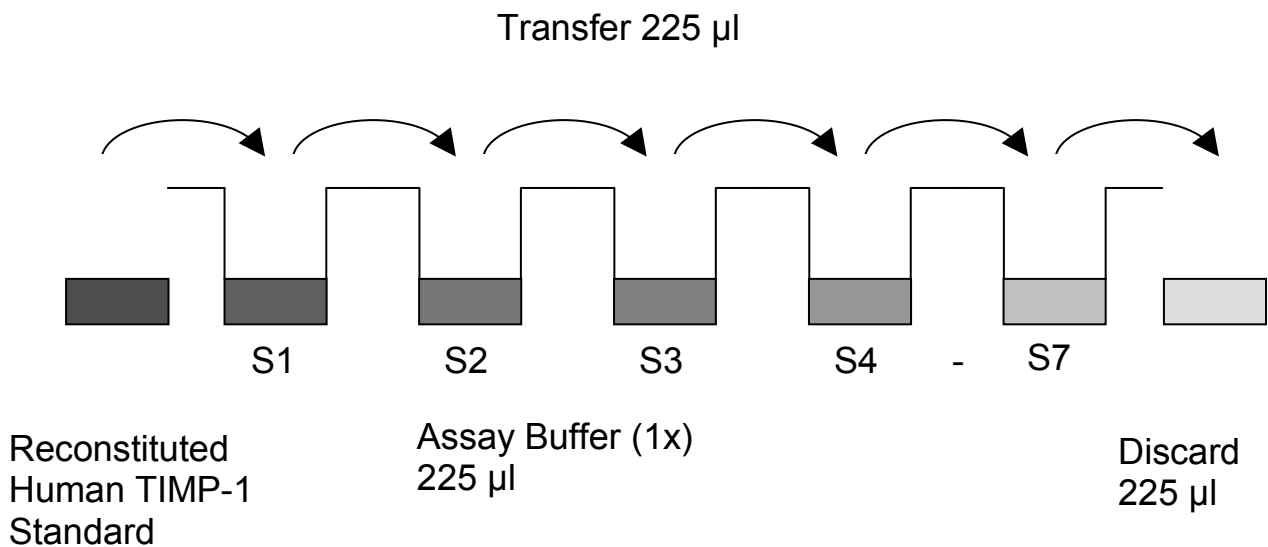

9.6 Addition of Colour-giving Reagents: Blue-Dye, Green-Dye, Red-Dye

This procedure is optional, does not in any way interfere with the test results, and is designed to help the customer with the performance of the test, but can also be omitted, just following the instruction booklet.

Alternatively, the dye solutions from the stocks provided (**Blue-Dye, Green-Dye, Red-Dye**) can be added to the reagents according to the following guidelines:

1. Diluent:

Before standard and sample dilution add the **Blue-Dye** at a dilution of 1:250 (see table below) to the appropriate diluent (1x) according to the test protocol. After addition of **Blue-Dye**, proceed according to the instruction booklet.

5 ml Assay Buffer (1x)	20 µl Blue-Dye
12 ml Assay Buffer (1x)	48 µl Blue-Dye
50 ml Assay Buffer (1x)	200 µl Blue-Dye

2. Biotin-Conjugate:

Before dilution of the concentrated Biotin-Conjugate, add the **Green-Dye** at a dilution of 1:100 (see table below) to the Assay Buffer (1x) used for the final conjugate dilution. Proceed after addition of **Green-Dye** according to the instruction booklet: Preparation of Biotin-Conjugate.

3 ml Assay Buffer (1x)	30 µl Green-Dye
6 ml Assay Buffer (1x)	60 µl Green-Dye

3. Streptavidin-HRP:

Before dilution of the concentrated Streptavidin-HRP, add the **Red-Dye** at a dilution of 1:250 (see table below) to the Assay Buffer (1x) used for the final Streptavidin-HRP dilution. Proceed after addition of **Red-Dye** according to the instruction booklet: Preparation of Streptavidin-HRP.

6 ml Assay Buffer (1x)	24 µl Red-Dye
12 ml Assay Buffer (1x)	48 µl Red-Dye

10 TEST PROTOCOL

- a. Predilute your samples before starting with the test procedure. Dilute serum, plasma 1:100 with Assay Buffer (1x) according to the following scheme: 10 µl sample + 990 µl Assay Buffer (1x)
- b. Determine the number of microwell strips required to test the desired number of samples plus appropriate number of wells needed for running blanks and standards. Each sample, standard, blank and optional control sample should be assayed in duplicate. Remove extra microwell strips from holder and store in foil bag with the desiccant provided at 2°-8°C sealed tightly.
- c. Wash the microwell strips twice with approximately 400 µl **Wash Buffer** per well with thorough aspiration of microwell contents between washes. Allow the Wash Buffer to sit in the wells for about **10 – 15 seconds** before aspiration. Take care not to scratch the surface of the microwells. After the last wash step, empty wells and tap microwell strips on absorbent pad or paper towel to remove excess Wash Buffer. Use the microwell strips immediately after washing. Alternatively microwell strips can be placed upside down on a wet absorbent paper for not longer than 15 minutes. **Do not allow wells to dry.**
- d. **Standard dilution on the microwell plate** (Alternatively the standard dilution can be prepared in tubes - see 9.5.1.): Add 100 µl of Assay Buffer (1x) in duplicate to all **standard wells**. Pipette 100 µl of reconstituted **standard** (see Preparation of Standard 9.5, concentration = 5000 pg/ml) in duplicate into wells A1 and A2 (see Table 1). Mix the contents of wells A1 and A2 by repeated aspiration and ejection (concentration of standard 1, S1 = 2500 pg/ml), and transfer 100 µl to wells B1 and B2, respectively. (see Figure 7). Take care not to scratch the inner surface of the microwells. Continue this procedure 5 times, creating two rows of human TIMP-1 standard dilutions ranging from 2500 to 39 pg/ml. Discard 100 µl of the contents from the last microwells (G1, G2) used.

Figure 7

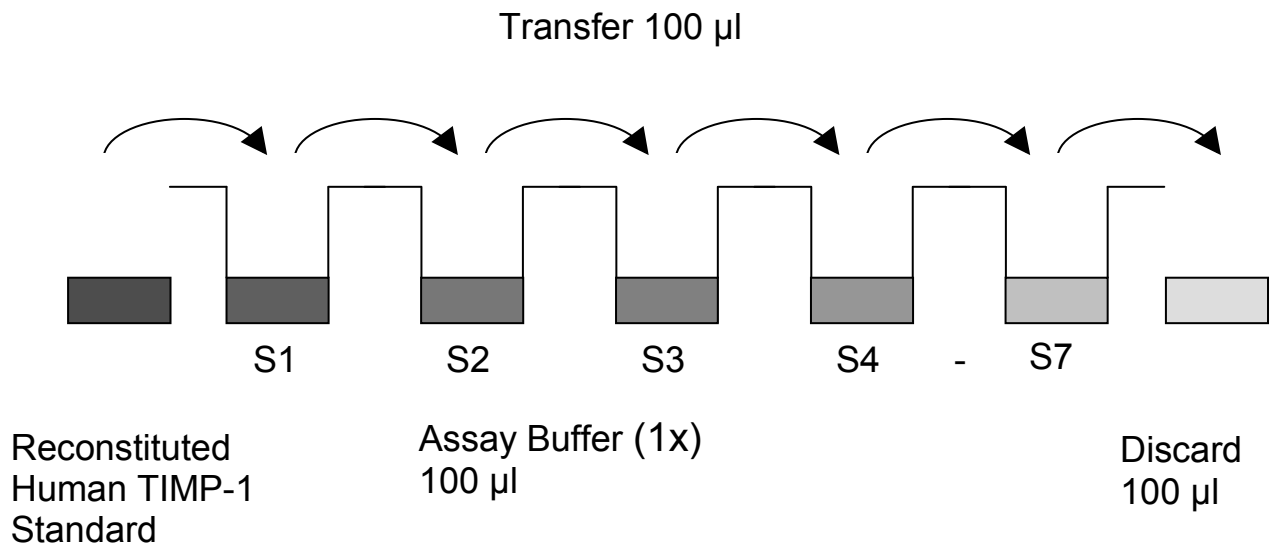

In case of an **external standard dilution** (see 9.5.1.), pipette 100 µl of these standard dilutions (S1 -S7) in the standard wells according to Table 1.

Table 1

Table depicting an example of the arrangement of blanks, standards and samples in the microwell strips:

	1	2	3	4
A	Standard 1 (2500 pg/ml)	Standard 1 (2500 pg/ml)	Sample 1	Sample 1
B	Standard 2 (1250 pg/ml)	Standard 2 (1250 pg/ml)	Sample 2	Sample 2
C	Standard 3 (625 pg/ml)	Standard 3 (625 pg/ml)	Sample 3	Sample 3
D	Standard 4 (313 pg/ml)	Standard 4 (313 pg/ml)	Sample 4	Sample 4
E	Standard 5 (156 pg/ml)	Standard 5 (156 pg/ml)	Sample 5	Sample 5
F	Standard 6 (78 pg/ml)	Standard 6 (78 pg/ml)	Sample 6	Sample 6
G	Standard 7 (39 pg/ml)	Standard 7 (39 pg/ml)	Sample 7	Sample 7
H	Blank	Blank	Sample 8	Sample 8

- e. Add 100 µl of **Assay Buffer (1x)** in duplicate to the **blank wells**.
- f. Add 80 µl of **Assay Buffer (1x)** to the **sample wells**.
- g. Add 20 µl of each **sample** in duplicate to the **sample wells**.
- h. Prepare **Biotin-Conjugate** (see Preparation of Biotin-Conjugate 9.3).
- i. Add 50 µl of **Biotin-Conjugate** to all wells.
- j. Cover with an adhesive film and incubate at room temperature (18 to 25°C) for 2 hours, if available on a microplate shaker set at 100 rpm.
- k. Prepare **Streptavidin-HRP** (refer to Preparation of Streptavidin-HRP 9.4.).
- l. Remove adhesive film and empty wells. **Wash** microwell strips 6 times according to point c. of the test protocol. Proceed immediately to the next step.
- m. Add 100 µl of diluted **Streptavidin-HRP** to all wells, including the blank wells.
- n. Cover with an adhesive film and incubate at room temperature (18° to 25°C) for 1 hour, if available on a microplate shaker set at 100 rpm.
- o. Remove adhesive film and empty wells. **Wash** microwell strips 6 times according to point c. of the test protocol. Proceed immediately to the next step.
- p. Pipette 100 µl of **TMB Substrate Solution** to all wells.

- q. Incubate the microwell strips at room temperature (18° to 25°C) for about 10 min. Avoid direct exposure to intense light.

The colour development on the plate should be monitored and the substrate reaction stopped (see next point of this protocol) before positive wells are no longer properly recordable. Determination of the ideal time period for colour development has to be done individually for each assay.

It is recommended to add the stop solution when the highest standard has developed a dark blue colour. Alternatively the colour development can be monitored by the ELISA reader at 620 nm. The substrate reaction should be stopped as soon as Standard 1 has reached an OD of 0.6 – 0.65.

- r. Stop the enzyme reaction by quickly pipetting 100 µl of **Stop Solution** into each well. It is important that the Stop Solution is spread quickly and uniformly throughout the microwells to completely inactivate the enzyme. Results must be read immediately after the Stop Solution is added or within one hour if the microwell strips are stored at 2 - 8°C in the dark.
- s. Read absorbance of each microwell on a spectro-photometer using 450 nm as the primary wave length (optionally 620 nm as the reference wave length; 610 nm to 650 nm is acceptable). Blank the plate reader according to the manufacturer's instructions by using the blank wells. Determine the absorbance of both the samples and the standards.

Note: In case of incubation without shaking the obtained O.D. values may be lower than indicated below. Nevertheless the results are still valid.

11 CALCULATION OF RESULTS

- Calculate the average absorbance values for each set of duplicate standards and samples. Duplicates should be within 20 per cent of the mean value.
- Create a standard curve by plotting the mean absorbance for each standard concentration on the ordinate against the human TIMP-1 concentration on the abscissa. Draw a best fit curve through the points of the graph (a 5-parameter curve fit is recommended).
- To determine the concentration of circulating human TIMP-1 for each sample, first find the mean absorbance value on the ordinate and extend a horizontal line to the standard curve. At the point of intersection, extend a vertical line to the abscissa and read the corresponding human TIMP-1 concentration.
- **If instructions in this protocol have been followed samples have been diluted 1:500 (20 µl 1:100 prediluted sample + 80µl Assay Buffer (1x)), the concentration read from the standard curve must be multiplied by the dilution factor (x 500).**
- **Calculation of samples with a concentration exceeding standard 1 will result in incorrect, low human TIMP-1 levels (Hook Effect). Such samples require further external predilution according to expected human TIMP-1 values with Assay Buffer (1x) in order to precisely quantitate the actual human TIMP-1 level.**
- It is suggested that each testing facility establishes a control sample of known human TIMP-1 concentration and runs this additional control with each assay. If the values obtained are not within the expected range of the control, the assay results may be invalid.
- A representative standard curve is shown in Figure 8. This curve cannot be used to derive test results. Each laboratory must prepare a standard curve for each group of microwell strips assayed.

Figure 8

Representative standard curve for human TIMP-1 ELISA. Human TIMP-1 was diluted in serial 2-fold steps in Assay Buffer (1x). Do not use this standard curve to derive test results. A standard curve must be run for each group of microwell strips assayed.

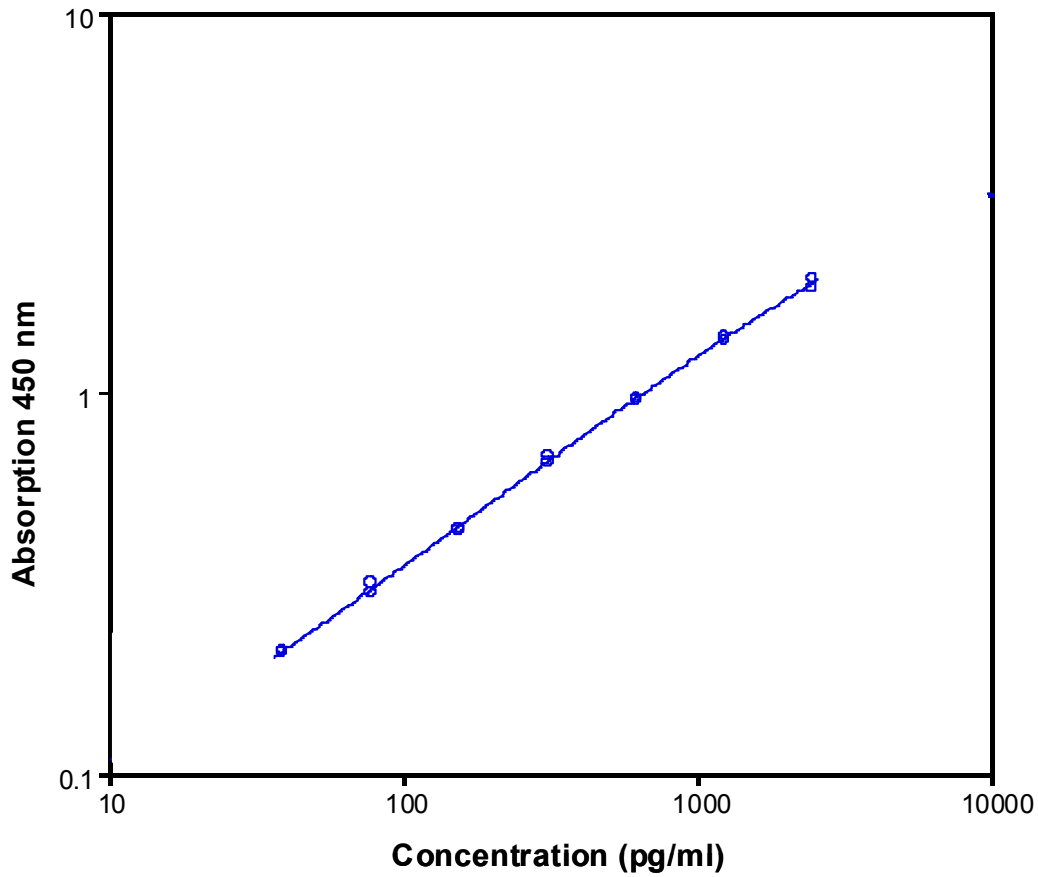

Table 2

Typical data using the human TIMP-1 ELISA

Measuring wavelength: 450 nm

Reference wavelength: 620 nm

Standard	Human TIMP-1 Concentration (pg/ml)	O.D. at 450 nm	Mean O.D. at 450 nm	C.V. (%)
1	2500	2.002 1.892	1.947	2.8
2	1250	1.409 1.377	1.393	1.1
3	625	0.978 0.960	0.969	0.9
4	313	0.655 0.683	0.669	2.1
5	156	0.444 0.436	0.440	0.9
6	78	0.318 0.298	0.308	3.3
7	39	0.208 0.211	0.210	0.8
Blank	0	0.1203 0.118	0.119	0.8

The OD values of the standard curve may vary according to the conditions of assay performance (e.g. operator, pipetting technique, washing technique or temperature effects). Furthermore shelf life of the kit may affect enzymatic activity and thus colour intensity. Values measured are still valid.

12 LIMITATIONS

- Since exact conditions may vary from assay to assay, a standard curve must be established for every run.
- Bacterial or fungal contamination of either screen samples or reagents or cross-contamination between reagents may cause erroneous results.
- Disposable pipette tips, flasks or glassware are preferred, reusable glassware must be washed and thoroughly rinsed of all detergents before use.
- Improper or insufficient washing at any stage of the procedure will result in either false positive or false negative results. Empty wells completely before dispensing fresh wash solution, fill with Wash Buffer as indicated for each wash cycle and do not allow wells to sit uncovered or dry for extended periods.
- The use of radioimmunotherapy has significantly increased the number of patients with human anti-mouse IgG antibodies (HAMA). HAMA may interfere with assays utilizing murine monoclonal antibodies leading to both false positive and false negative results. Serum samples containing antibodies to murine immunoglobulins can still be analysed in such assays when murine immunoglobulins (serum, ascitic fluid, or monoclonal antibodies of irrelevant specificity) are added to the sample.

13 PERFORMANCE CHARACTERISTICS

13.1 Sensitivity

The limit of detection of human TIMP-1 defined as the analyte concentration resulting in an absorbance significantly higher than that of the dilution medium (mean plus 2 standard deviations) was determined to be 10 ng/ml (mean of 6 independent assays).

13.2 Reproducibility

13.2.1 Intra-assay

Reproducibility within the assay was evaluated in 3 independent experiments. Each assay was carried out with 6 replicates of 8 serum samples containing different concentrations of human TIMP-1. 2 standard curves were run on each plate. Data below show the mean human TIMP-1 concentration and the coefficient of variation for each sample (see Table 3). The calculated overall intra-assay coefficient of variation was 4.9%.

Table 3

The mean human TIMP-1 concentration and the coefficient of variation for each sample

Sample	Experiment	Mean Human TIMP-1 Concentration (pg/ml)	Coefficient of Variation (%)
1	1	230	3.5
	2	232	4.5
	3	242	4.6
2	1	219	4.0
	2	216	2.8
	3	227	5.5
3	1	197	3.8
	2	197	4.7
	3	211	3.0
4	1	99	3.4
	2	102	6.8
	3	103	4.4
5	1	508	6.1
	2	517	2.6
	3	553	7.2
6	1	169	5.9
	2	150	3.7
	3	158	2.7
7	1	197	6.0
	2	178	5.2
	3	192	6.1
8	1	180	7.8
	2	165	4.6
	3	177	8.6

13.2.2 Inter-assay

Assay to assay reproducibility within one laboratory was evaluated in 3 independent experiments. Each assay was carried out with 6 replicates of 8 serum samples containing different concentrations of human TIMP-1. 2 standard curves were run on each plate. Data below show the mean human TIMP-1 concentration and the coefficient of variation calculated on 18 determinations of each sample (see Table 4). The calculated overall inter-assay coefficient of variation was 3.9%.

Table 4

The mean human TIMP-1 concentration and the coefficient of variation of each sample

Sample	Mean Human TIMP-1 Concentration (pg/ml)	Coefficient of Variation (%)
1	235	2.7
2	220	2.7
3	202	4.0
4	101	1.7
5	526	4.5
6	159	6.1
7	189	5.1
8	174	4.5

13.3 Spiking Recovery

The spiking recovery was evaluated by spiking 4 levels of human TIMP-1 into serum. Recoveries were determined in 3 independent experiments with 4 replicates each. The unspiked serum was used as blank in these experiments. The amount of endogenous human TIMP-1 in unspiked serum was subtracted from the spike values.

The recovery ranged from 74% to 121% with an overall mean recovery of 92.9%.

13.4 Dilution Linearity

Serum samples with different levels of human TIMP-1 were analysed at serial 2 fold dilutions with 4 replicates each.

The recovery ranged from 87.1% to 105.3% with an overall recovery of 97.5% (see Table 5).

Table 5

Sample	Dilution	Expected Human TIMP-1 Concentration (pg/ml)	Observed Human TIMP-1 Concentration (pg/ml)	Recovery of Expected Human TIMP-1 Concentration (%)
1	500		536	
	1000	268	282	105.3
	2000	134	141	105.3
	4000	67	70	104.3
2	500		204	
	1000	102	96	94.1
	2000	51	44	87.1
	4000	25	24	94.6
3	500		182	
	1000	91	91	99.9
	2000	46	45	98.3
	4000	23	20	89.6
4	500		168	
	1000	84	84	99.5
	2000	42	39	92.5
	4000	21	21	98.9

13.5 Sample Stability

13.5.1 Freeze-Thaw Stability

Aliquots of serum samples (spiked or unspiked) were stored at -20°C and thawed 5 times, and the human TIMP-1 levels determined. There was no significant loss of human TIMP-1 immunoreactivity detected by freezing and thawing.

13.5.2 Storage Stability

Aliquots of serum (spiked or unspiked) were stored at -20°C, 2-8°C, room temperature (RT) and at 37°C, and the human TIMP-1 level determined after 72 h. There was no significant loss of human TIMP-1 immunoreactivity detected during storage under above conditions.

13.6 Specificity

The assay detects both natural and recombinant human TIMP-1. To define the specificity of this ELISA several proteins were tested for cross reactivity. There was no crossreactivity detected.

13.7 Expected Values

A panel of sera and plasma samples from randomly selected apparently healthy donors (males and females) was tested for human TIMP-1. The detected human TIMP-1 levels ranged between 11 and 743 ng/ml with a mean level of 172 ng/ml and a standard deviation of 130 ng/ml for sera samples, between 9 and 321 ng/ml with a mean level of 112 ng/ml and a standard deviation of 64 ng/ml for plasma (EDTA) samples and between 134 and 549 ng/ml with a mean level of 245 ng/ml and a standard deviation of 110 ng/ml for plasma (heparinized) samples.

14 REFERENCES

- 1) Arthur MJ, Iredale JP. Hepatic lipocytes, TIMP-1 and liver fibrosis. *J R Coll Physicians Lond*. 1994 May-Jun; 28(3): 200-8.
- 2) Gardner J, Ghorpade A. Tissue inhibitor of metalloproteinase (TIMP)-1: The TIMPed balance of matrix metalloproteinases in the central nervous system. *J Neurosci Res*. 2003 Dec 15; 74(6):801-6.
- 3) Hornebeck W. Down-regulation of tissue inhibitor of matrix metalloprotease-1 (TIMP-1) in aged human skin contributes to matrix degradation and impaired cell growth and survival. *Pathol Biol (Paris)*. 2003 Dec; 51(10): 569-73.
- 4) Nagase H, Brew K. Designing TIMP (tissue inhibitor of metalloproteinases) variants that are selective metalloproteinase inhibitors. *Biochem Soc Symp*. 2003; (70): 201-12.
- 5) Nagase H, Meng Q, Malinovskii V, Huang W, Chung L, Bode W, Maskos K, Brew K. Engineering of selective TIMPs. *Ann N Y Acad Sci*. 1999 Jun 30; 878: 1-11.
- 6) Shin WS, Szuba A, Rockson SG. The role of chemokines in human cardiovascular pathology: enhanced biological insights. *Atherosclerosis*. 2002 Jan; 160(1): 91-102.
- 7) Thorgeirsson UP, Lindsay CK, Cottam DW, Gomez DE. Tumor invasion, proteolysis, and angiogenesis. *J Neurooncol*. 1994; 18(2): 89-103.
- 8) Wojtowicz-Praga SM, Dickson RB, Hawkins MJ. Matrix metalloproteinase inhibitors. *Invest New Drugs*. 1997; 15(1): 61-75.
- 9) Yan L, Moses MA. A case of tumor betrayal: biphasic effects of TIMP-1 on Burkitt's lymphoma. *Am J Pathol*. 2001 Apr; 158(4): 1185-90.

15 REAGENT PREPARATION SUMMARY

15.1 Wash Buffer

Add **Wash Buffer Concentrate** 20x (50 ml) to 950 ml distilled water.

Number of Strips	Wash Buffer Concentrate (20x) (ml)	Distilled Water (ml)
1 - 6	25	475
1 - 12	50	950

15.2 Assay Buffer (1x)

Add **Assay Buffer Concentrate** 20x (5 ml) to 95 ml distilled water.

Number of Strips	Assay Buffer Concentrate (20x) (ml)	Distilled Water (ml)
1 - 6	2.5	47.5
1 - 12	5.0	95.0

15.3 Biotin-Conjugate

Make a 1:100 dilution of **Biotin-Conjugate** in Assay Buffer (1x):

Number of Strips	Biotin-Conjugate (ml)	Assay Buffer (1x) (ml)
1 - 6	0.03	2.97
1 - 12	0.06	5.94

15.4 Streptavidin-HRP

Make a 1:100 dilution of **Streptavidin-HRP** in Assay Buffer (1x):

Number of Strips	Streptavidin-HRP (ml)	Assay Buffer (1x) (ml)
1 - 6	0.06	5.94
1 - 12	0.12	11.88

15.5 Human TIMP-1 Standard

Reconstitute lyophilized **human TIMP-1 standard** with distilled water (1x). (Reconstitution volume is stated on the label of the standard vial.)

16 TEST PROTOCOL SUMMARY

1. Predilute sample with Assay Buffer (1x) 1:100.
2. Determine the number of microwell strips required.
3. Wash microwell strips twice with Wash Buffer.
4. Standard dilution on the microwell plate: Add 100 µl Assay Buffer (1x), in duplicate, to all standard wells. Pipette 100 µl prepared standard into the first wells and create standard dilutions by transferring 100 µl from well to well. Discard 100 µl from the last wells.
Alternatively external standard dilution in tubes (see 9.5.1): Pipette 100 µl of these standard dilutions in the microwell strips.
5. Add 100 µl Assay Buffer (1x), in duplicate, to the blank wells.
6. Add 80 µl Assay Buffer (1x) to sample wells.
7. Add 20 µl sample in duplicate, to designated sample wells.
8. Prepare Biotin-Conjugate.
9. Add 50 µl Biotin-Conjugate to all wells.
10. Cover microwell strips and incubate 2 hours at room temperature (18° to 25°C).
11. Prepare Streptavidin-HRP.
12. Empty and wash microwell strips 6 times with Wash Buffer.
13. Add 100 µl diluted Streptavidin-HRP to all wells.
14. Cover microwell strips and incubate 1 hour at room temperature (18° to 25°C).
15. Empty and wash microwell strips 6 times with Wash Buffer.
16. Add 100 µl of TMB Substrate Solution to all wells.
17. Incubate the microwell strips for about 10 minutes at room temperature (18° to 25°C).
18. Add 100 µl Stop Solution to all wells.
19. Blank microwell reader and measure colour intensity at 450 nm.

Note: If instructions in this protocol have been followed samples have been diluted 1:500 (20 µl 1:100 prediluted µl sample + 80 µl Assay Buffer (1x)), the concentration read from the standard curve must be multiplied by the dilution factor (x 500).

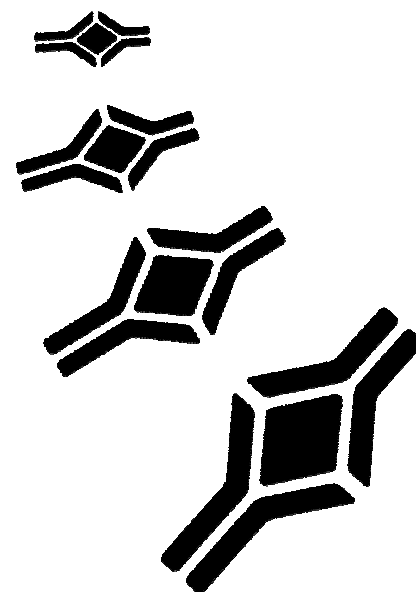

HEADQUARTERS:				
BioVendor Laboratorní medicína, a.s.	CTPark Modrice Evropska 873	664 42 Modrice CZECH REPUBLIC	Phone: +420-549-124-185 Fax: +420-549-211-460	E-mail: info@biovendor.com Web: www.biovendor.com
EUROPEAN UNION: BioVendor GmbH	Im Neuenheimer Feld 583	D-69120 Heidelberg GERMANY	Phone: +49-6221-433-9100 Fax: +49-6221-433-9111	E-mail: infoEU@biovendor.com
USA, CANADA AND MEXICO: BioVendor LLC	1463 Sand Hill Road Suite 227	Candler, NC 28715 USA	Phone: +1-828-670-7807 +1-800-404-7807 Fax: +1-828-670-7809	E-mail: infoUSA@biovendor.com
CHINA - Hong Kong Office: BioVendor Laboratories Ltd	Room 4008 Hong Kong Plaza, No.188	Connaught Road West Hong Kong, CHINA	Phone: +852-2803-0523 Fax: +852-2803-0525	E-mail: infoHK@biovendor.com
CHINA – Mainland Office: BioVendor Laboratories Ltd	Room 2405 YiYa Tower TianYu Garden, No.150	Lihe Zhong Road Guang Zhou, CHINA	Phone: +86-20-8706-3029 Fax: +86-20-8706-3016	E-mail: infoCN@biovendor.com