

BioVendor

Research
and Diagnostic Products

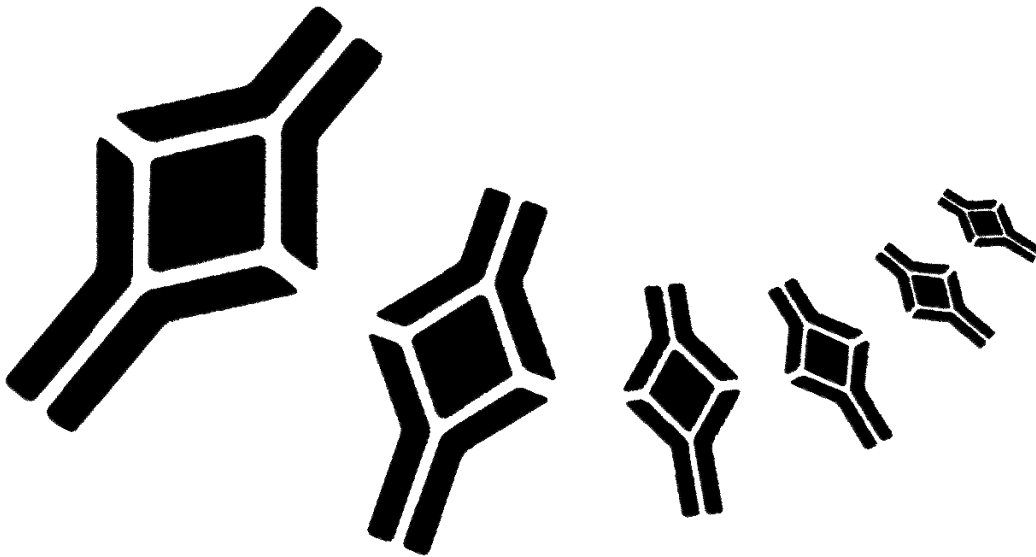

HUMAN sTNF-R (60 kDa) ELISA

Product Data Sheet

Cat. No.: RBMS203R

For Research Use Only

CONTENTS

1	Intended Use	3
2	Summary	3
3	Principles of the Test	5
4	Reagents Provided	6
5	Storage Instructions – ELISA Kit	7
6	Specimen Collection and Storage Instructions	7
7	Materials Required But Not Provided	8
8	Precautions for Use	9
9	Preparation of Reagents	11
10	Test Protocol	15
11	Calculation of Results	20
12	Limitations	23
13	Performance Characteristics	24
14	References	29
15	Reagent Preparation Summary	33
16	Test Protocol Summary	34

**»» This kit is manufactured by:
BioVendor – Laboratorní medicína, a.s.**

»» Use only the current version of Product Data Sheet enclosed with the kit!

1 INTENDED USE

The human sTNF-R (60 kDa) ELISA is an enzyme-linked immunosorbent assay for the quantitative detection of human sTNF-R (60 kDa). **The human sTNF-R (60 kDa) ELISA is for research use only. Not for diagnostic or therapeutic procedures.**

2 SUMMARY

Tumor Necrosis Factor (TNF) was originally discovered in sera of animals and was found to cause hemorrhagic necrosis of some transplantable mouse and human tumors and to exhibit primarily cytotoxic activities against tumor but not normal cells in vitro (8, 15). The TNF family consists of two proteins designated $TNF\alpha$, also called cachectin (6), and $TNF\beta$, also called lymphotoxin (17), which are pleiotropic cytokines that can mediate a wide variety of biological effects (3).

Both $TNF\alpha$ and $TNF\beta$ have been shown to interact with a cell through specific high affinity receptors with a few hundred up to more than 20,000 copies per cell (4, 9, 12, 14, 18, 20, 21, 25). TNF-receptors have been demonstrated on a wide variety of human somatic cells including fibroblasts (12), endothelial cells, adipocytes, liver membranes (5), granulocytes and several tumor cell lines (2, 7, 9, 24). Normal and malignant human myeloid cells as well as mitogen-stimulated lymphocytes express similar numbers of TNF receptors (400 - 1,900 per cell), whereas resting lymphoid cells have fewer, red blood cells and platelets have no detectable TNF receptors (14).

In most cases no correlation is observed between receptor number and sensitivity to TNF. Based on gel filtration experiments the receptor appears to be a complex of different proteins with a molecular weight of 350 kDa. In a variety of cell lines two different types of TNF receptors with 75-80 and 55-60 kDa respectively have been identified (7,11,23).

The cDNAs encoding the two different TNF receptors have been cloned (10, 13, 19, 22). The exact mechanism of signal transduction after binding of TNF to the receptor is still unclear. The extracellular fragment of the 60 kDa TNF receptor, with a molecular mass of about 30 kDa was purified, partially sequenced, and the respective cDNA was cloned (10, 16, 19). This TNF binding protein is liberated from the intact molecule by proteolytic cleavage and comprises most of the extracellular portion of the receptor, including all three N-glycosylation sites.

The present assay, slightly modified from the assay established by Adolf and Apfler (1), provides a simple, rapid, and highly sensitive method for the determination of soluble TNF-R (60 kDa) levels in body fluids or cell culture supernatants. This assay will help to clarify the possible diagnostic and prognostic value of circulating sTNF-R (60 kDa) in various neoplastic and inflammatory diseases.

3 PRINCIPLES OF THE TEST

An anti-human sTNF-R (60 kDa) coating antibody is adsorbed onto microwells.

Figure 1

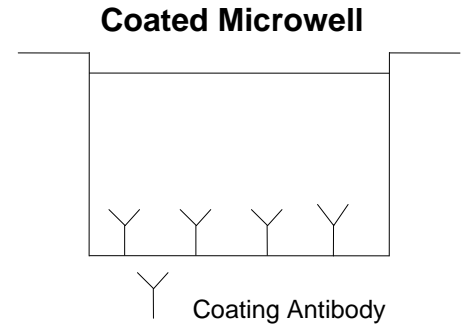

Human sTNF-R (60 kDa) present in the sample or standard binds to antibodies adsorbed to the microwells. A HRP-conjugated anti-human sTNF-R (60 kDa) antibody is added and binds to human sTNF-R (60 kDa) captured by the first antibody.

Figure 2

First Incubation

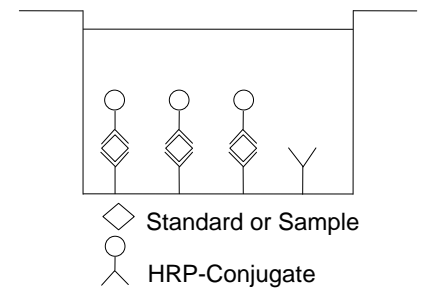

Following incubation unbound HRP-conjugated anti-human sTNF-R (60 kDa) is removed during a wash step, and substrate solution reactive with HRP is added to the wells.

Figure 3

Second Incubation

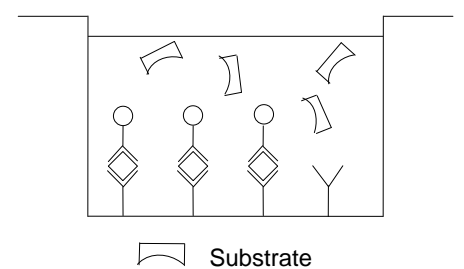

A coloured product is formed in proportion to the amount of human sTNF-R (60 kDa) present in the sample or standard. The reaction is terminated by addition of acid and absorbance is measured at 450 nm. A standard curve is prepared from 7 human sTNF-R (60 kDa) standard dilutions and human sTNF-R (60 kDa) concentration determined.

Figure 4

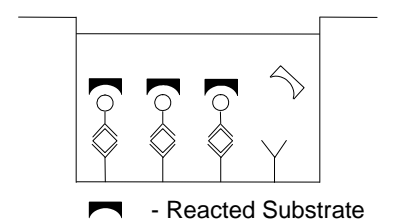

4 REAGENTS PROVIDED

- 1 aluminium pouch with a **Antibody Coated Microtiter Strips** with monoclonal antibody to human sTNF-R (60 kDa)
- 1 vial (200 µl) **HRP-Conjugate** anti-human sTNF-R (60 kDa) monoclonal antibody
- 2 vials (50 µl) human sTNF-R (60 kDa) **Standard** concentrate
- 1 vial **Control**, lyophilized
- 1 vial (5 ml) **Assay Buffer Concentrate** 20x (PBS with 1% Tween 20 and 10% BSA)
- 1 bottle (50 ml) **Wash Buffer Concentrate** 20x (PBS with 1% Tween 20)
- 1 vial (15 ml) **Substrate Solution** (tetramethyl-benzidine)
- 1 vial (12 ml) **Stop Solution** (1M Phosphoric acid)
- 1 vial (0.4 ml) **Blue-Dye**
- 1 vial (0.4 ml) **Green-Dye**
- 2 **Adhesive Films**

5 STORAGE INSTRUCTIONS – ELISA KIT

Store kit reagents between 2° and 8°C except controls. Store lyophilized controls at -20°C.

Immediately after use remaining reagents should be returned to cold storage (2° to 8°C), controls to -20°C, respectively. Expiry of the kit and reagents is stated on labels.

Expiry of the kit components can only be guaranteed if the components are stored properly, and if, in case of repeated use of one component, this reagent is not contaminated by the first handling.

6 SPECIMEN COLLECTION AND STORAGE INSTRUCTIONS

Cell culture supernatant, serum, plasma (EDTA, citrate, heparin) and urine were tested with this assay. (Determination of human sTNF-R (60 kDa) in urine requires a modified procedure, see 9.3 Other biological samples might be suitable for use in the assay. Remove serum or plasma from the clot or cells as soon as possible after clotting and separation.

Pay attention to a possible “**Hook Effect**” due to high sample concentrations (see chapter 11).

Samples containing a visible precipitate must be clarified prior to use in the assay. Do not use grossly hemolyzed or lipemic specimens.

Samples should be aliquoted and must be stored frozen at -20°C to avoid loss of bioactive human sTNF-R (60 kDa). If samples are to be run within 24 hours, they may be stored at 2° to 8°C (for sample stability refer to 13.5).

Avoid repeated freeze-thaw cycles. Prior to assay, the frozen sample should be brought to room temperature slowly and mixed gently.

7 MATERIALS REQUIRED BUT NOT PROVIDED

- 5 ml and 10 ml graduated pipettes
- 5 μl to 1000 μl adjustable single channel micropipettes with disposable tips
- 50 μl to 300 μl adjustable multichannel micropipette with disposable tips
- Multichannel micropipette reservoir
- Beakers, flasks, cylinders necessary for preparation of reagents
- Device for delivery of wash solution (multichannel wash bottle or automatic wash system)
- Microwell strip reader capable of reading at 450 nm (620 nm as optional reference wave length)
- Glass-distilled or deionized water
- Statistical calculator with program to perform regression analysis

8 PRECAUTIONS FOR USE

- All chemicals should be considered as potentially hazardous. We therefore recommend that this product is handled only by those persons who have been trained in laboratory techniques and that it is used in accordance with the principles of good laboratory practice. Wear suitable protective clothing such as laboratory overalls, safety glasses and gloves. Care should be taken to avoid contact with skin or eyes. In the case of contact with skin or eyes wash immediately with water. See material safety data sheet(s) and/or safety statement(s) for specific advice.
- Reagents are intended for in vitro diagnostic use and are not for use in therapeutic procedures.
- Do not mix or substitute reagents with those from other lots or other sources.
- Do not use kit reagents beyond expiration date on label.
- Do not expose kit reagents to strong light during storage or incubation.
- Do not pipette by mouth.
- Do not eat or smoke in areas where kit reagents or samples are handled.
- Avoid contact of skin or mucous membranes with kit reagents or specimens.
- Rubber or disposable latex gloves should be worn while handling kit reagents or specimens.
- Avoid contact of substrate solution with oxidizing agents and metal.
- Avoid splashing or generation of aerosols.
- In order to avoid microbial contamination or cross-contamination of reagents or specimens which may invalidate the test use disposable pipette tips and/or pipettes.

- Use clean, dedicated reagent trays for dispensing the conjugate and substrate reagent.
- Exposure to acid inactivates the conjugate.
- Glass-distilled water or deionized water must be used for reagent preparation.
- Substrate solution must be at room temperature prior to use.
- Decontaminate and dispose specimens and all potentially contaminated materials as they could contain infectious agents. The preferred method of decontamination is autoclaving for a minimum of 1 hour at 121.5°C.
- Liquid wastes not containing acid and neutralized waste may be mixed with sodium hypochlorite in volumes such that the final mixture contains 1.0% sodium hypochlorite. Allow 30 minutes for effective decontamination. Liquid waste containing acid must be neutralized prior to the addition of sodium hypochlorite.

9 PREPARATION OF REAGENTS

Buffer concentrates should be brought to room temperature and should be diluted before starting the test procedure.

9.1 Wash Buffer

If crystals have formed in the **Wash Buffer Concentrate (20x)**, warm it gently until they have completely dissolved.

Pour entire contents (50 ml) of the Wash Buffer Concentrate (20x) into a clean 1000 ml graduated cylinder. Bring to final volume of 1000 ml with glass-distilled or deionized water. Mix gently to avoid foaming. The pH of the final solution should adjust to 7.4.

Transfer to a clean wash bottle and store at 2° to 25°C. Please note that Wash Buffer is stable for 30 days.

Wash Buffer may also be prepared as needed according to the following table:

Number of Strips	Wash Buffer Concentrate (20x) (ml)	Distilled Water (ml)
1 - 6	25	475
1 - 12	50	950

9.2 Assay Buffer (1x)

Pour the entire contents (5 ml) of the **Assay Buffer Concentrate (20x)** into a clean 100 ml graduated cylinder. Bring to final volume of 100 ml with distilled water. Mix gently to avoid foaming.

Store at 2° to 8°C. Please note that the Assay Buffer (1x) is stable for 30 days.

Assay Buffer (1x) may also be prepared as needed according to the following table:

Number of Strips	Assay Buffer Concentrate (20x) (ml)	Distilled Water (ml)
1 - 6	2.5	47.5
1 - 12	5.0	95.0

9.3 HRP-Conjugate

Please note that the HRP-Conjugate should be used within 30 minutes after dilution.

Make a 1:100 dilution (1:300 for urine samples) of the concentrated **HRP-Conjugate** solution with Assay Buffer (1x) in a clean plastic tube as needed according to the following table:

Number of Strips	HRP-Conjugate (ml)	Assay Buffer (1x) (ml)
1 - 6	0.03	2.97 (8.97)*
1 - 12	0.06	5.94 (17.94)*

* for urine samples

9.4 Human sTNF-R (60 kDa) Standard

Prepare **human sTNF-R (60 kDa) standard** by addition of Assay Buffer (1x) as stated on the label and mix gently (concentration of diluted standard = 10 ng/ml).

Standard dilutions can be prepared directly on the microwell plate (see 10.c) or alternatively in tubes (see 9.4.1).

9.4.1 External Standard Dilution

Label 7 tubes, one for each standard point.

S1, S2, S3, S4, S5, S6, S7

Then prepare 1:2 serial dilutions for the standard curve as follows:

Pipette 225 μ l of Assay Buffer (1x) into each tube.

Pipette 225 μ l of diluted standard (concentration = 10 ng/ml) into the first tube, labelled S1, and mix (concentration of standard 1 = 5 ng/ml).

Pipette 225 μ l of this dilution into the second tube, labelled S2, and mix thoroughly before the next transfer.

Repeat serial dilutions 5 more times thus creating the points of the standard curve (see Figure 5).

Assay Buffer (1x) serves as blank.

Figure 5

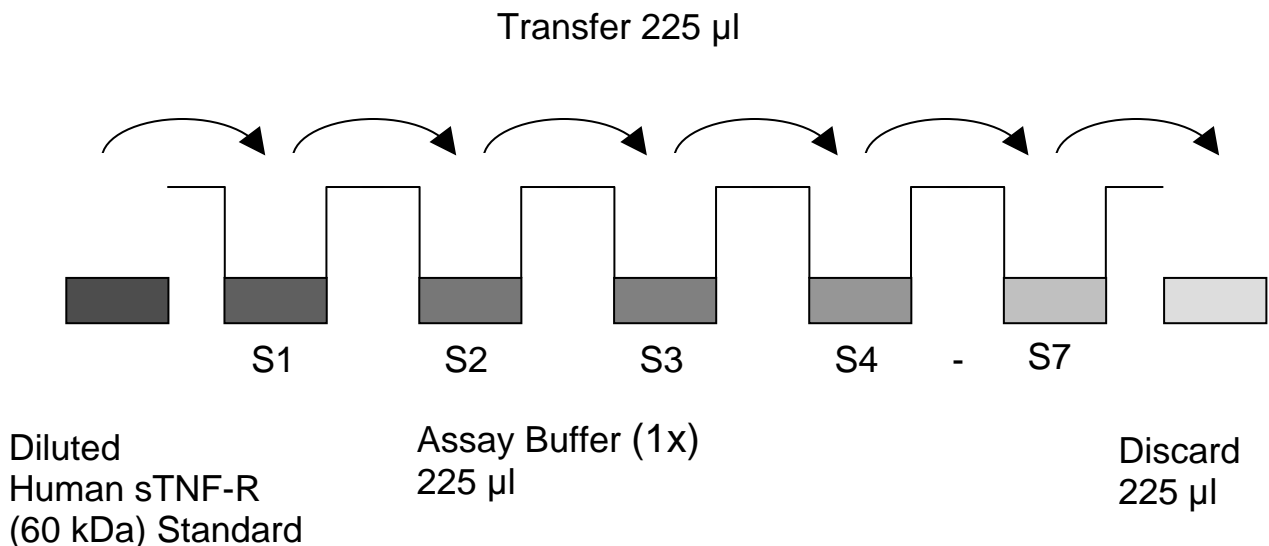

9.5 Control

Reconstitute by adding 100 μ l distilled water to lyophilized control. Swirl or mix gently to ensure complete and homogeneous solubilization. Further treat the control like your samples in the assay. For control range please refer to certificate of analysis or vial label. Store reconstituted control aliquoted at -20°C . Avoid repeated freeze and thaw cycles.

9.6 Addition of Colour-giving Reagents: Blue-Dye, Green-Dye

This procedure is optional, does not in any way interfere with the test results, and is designed to help the customer with the performance of the test, but can also be omitted, just following the instruction booklet.

Alternatively, the dye solutions from the stocks provided (**Blue-Dye**, **Green-Dye**) can be added to the reagents according to the following guidelines:

1. Diluent:

Before standard and sample dilution add the **Blue-Dye** at a dilution of 1:250 (see table below) to the appropriate diluent (1x) according to the test protocol. After addition of **Blue-Dye**, proceed according to the instruction booklet.

5 ml Assay Buffer (1x)	20 µl Blue-Dye
12 ml Assay Buffer (1x)	48 µl Blue-Dye
50 ml Assay Buffer (1x)	200 µl Blue-Dye

2. HRP-Conjugate:

Before dilution of the concentrated HRP-Conjugate add the **Green-Dye** at a dilution of 1:100 (see table below) to the Assay Buffer (1x) used for the final conjugate dilution. Proceed after addition of **Green-Dye** according to the instruction booklet: Preparation of HRP-Conjugate.

3 ml Assay Buffer (1x)	30 µl Green-Dye
6 ml Assay Buffer (1x)	60 µl Green-Dye
12 ml Assay Buffer (1x)	120 µl Green-Dye

10 TEST PROTOCOL

- a. Determine the number of microwell strips required to test the desired number of samples plus appropriate number of wells needed for running blanks and standards. Each sample, standard, blank and optional control sample should be assayed in duplicate. Remove extra microwell strips from holder and store in foil bag with the desiccant provided at 2°-8°C sealed tightly.
- b. Wash the microwell strips twice with approximately 400 µl **Wash Buffer** per well with thorough aspiration of microwell contents between washes. Allow the Wash Buffer to sit in the wells for about **10 – 15 seconds** before aspiration. Take care not to scratch the surface of the microwells. After the last wash step, empty wells and tap microwell strips on absorbent pad or paper towel to remove excess Wash Buffer. Use the microwell strips immediately after washing. Alternatively microwell strips can be placed upside down on a wet absorbent paper for not longer than 15 minutes. **Do not allow wells to dry.**
- c. **Standard dilution on the microwell plate** (Alternatively the standard dilution can be prepared in tubes - see 9.4.1): Add 100 µl of Assay Buffer (1x) in duplicate to all **standard wells**. Pipette 100 µl of diluted **standard** (see Preparation of Standard 9.4, concentration = 10 ng/ml) in duplicate into well A1 and A2 (see Table 1). Mix the contents of wells A1 and A2 by repeated aspiration and ejection (concentration of standard 1, S1 = 5 ng/ml), and transfer 100 µl to wells B1 and B2, respectively (see Figure 6). Take care not to scratch the inner surface of the microwells. Continue this procedure 5 times, creating two rows of human sTNF-R (60 kDa) standard dilutions ranging from 5.00 to 0.08 ng/ml. Discard 100 µl of the contents from the last microwells (G1, G2) used.

Figure 6

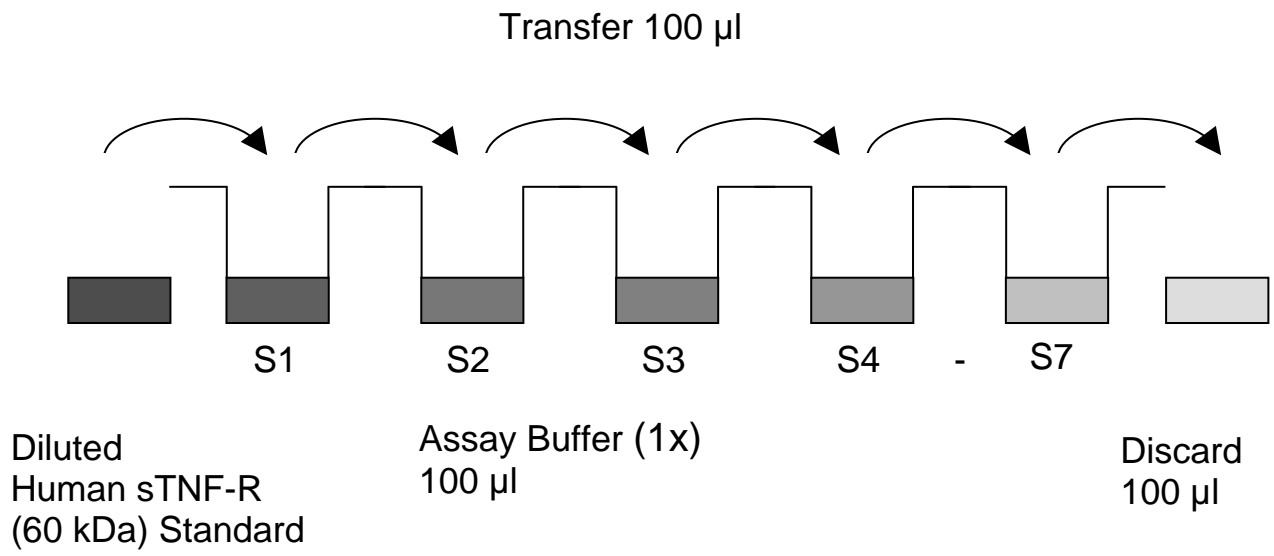

In case of an **external standard dilution** (see 9.4.1), pipette 100 µl of these standard dilutions (S1 - S7) in the standard wells according to Table 1.

Table 1

Table depicting an example of the arrangement of blanks, standards and samples in the microwell strips:

	1	2	3	4
A	Standard 1 (5.00 ng/ml)	Standard 1 (5.00 ng/ml)	Sample 1	Sample 1
B	Standard 2 (2.50 ng/ml)	Standard 2 (2.50 ng/ml)	Sample 2	Sample 2
C	Standard 3 (1.25 ng/ml)	Standard 3 (1.25 ng/ml)	Sample 3	Sample 3
D	Standard 4 (0.63 ng/ml)	Standard 4 (0.63 ng/ml)	Sample 4	Sample 4
E	Standard 5 (0.31 ng/ml)	Standard 5 (0.31 ng/ml)	Sample 5	Sample 5
F	Standard 6 (0.16 ng/ml)	Standard 6 (0.16 ng/ml)	Sample 6	Sample 6
G	Standard 7 (0.08 ng/ml)	Standard 7 (0.08 ng/ml)	Sample 7	Sample 7
H	Blank	Blank	Sample 8	Sample 8

- d. Add 100 µl of **Assay Buffer (1x)** in duplicate to the **blank wells**.
- e. Add 90 µl of **Assay Buffer (1x)** to the **sample wells**.
- f. Add 10 µl of each **sample** in duplicate to the **sample wells**.
- g. Prepare **HRP-Conjugate** (see Preparation of HRP-Conjugate 9.3).
- h. Add 50 µl (100 µl for urine samples) of **HRP-Conjugate** to all wells.
- i. Cover with an adhesive film and incubate at room temperature (18 to 25°C) for 2 hours, if available on a microplate shaker set at 100 rpm.
- j. Remove adhesive film and empty wells. **Wash** microwell strips 3 times according to point b. of the test protocol. Proceed immediately to the next step.
- k. Pipette 100 µl of **TMB Substrate Solution** to all wells.
- l. Incubate the microwell strips at room temperature (18° to 25°C) for about 10 min. Avoid direct exposure to intense light.

The colour development on the plate should be monitored and the substrate reaction stopped (see next point of this protocol) before positive wells are no longer properly recordable. Determination of the ideal time period for colour development has to be done individually for each assay.

It is recommended to add the stop solution when the highest standard has developed a dark blue colour. Alternatively the colour development can be monitored by the ELISA reader at 620 nm. The substrate reaction should be stopped as soon as Standard 1 has reached an OD of 0.6 – 0.65.

- m. Stop the enzyme reaction by quickly pipetting 100 μ l of **Stop Solution** into each well. It is important that the Stop Solution is spread quickly and uniformly throughout the microwells to completely inactivate the enzyme. Results must be read immediately after the Stop Solution is added or within one hour if the microwell strips are stored at 2 - 8°C in the dark.
- n. Read absorbance of each microwell on a spectro-photometer using 450 nm as the primary wave length (optionally 620 nm as the reference wave length; 610 nm to 650 nm is acceptable). Blank the plate reader according to the manufacturer's instructions by using the blank wells. Determine the absorbance of both the samples and the standards.

Note: In case of incubation without shaking the obtained O.D. values may be lower than indicated below. Nevertheless the results are still valid.

11 CALCULATION OF RESULTS

- Calculate the average absorbance values for each set of duplicate standards and samples. Duplicates should be within 20 per cent of the mean value.
- Create a standard curve by plotting the mean absorbance for each standard concentration on the ordinate against the human sTNF-R (60 kDa) concentration on the abscissa. Draw a best fit curve through the points of the graph (a 5-parameter curve fit is recommended).
- To determine the concentration of circulating human sTNF-R (60 kDa) for each sample, first find the mean absorbance value on the ordinate and extend a horizontal line to the standard curve. At the point of intersection, extend a vertical line to the abscissa and read the corresponding human sTNF-R (60 kDa) concentration.
- **If instructions in this protocol have been followed samples have been diluted 1:10 (10 µl sample + 90 µl Assay Buffer (1x)), the concentration read from the standard curve must be multiplied by the dilution factor (x 10).**
- **Calculation of samples with a concentration exceeding standard 1 may result in incorrect, low human sTNF-R (60 kDa) levels (Hook Effect). Such samples require further external predilution according to expected human sTNF-R (60 kDa) values with Assay Buffer (1x) in order to precisely quantitate the actual human sTNF-R (60 kDa) level.**
- It is suggested that each testing facility establishes a control sample of known human sTNF-R (60 kDa) concentration and runs this additional control with each assay. If the values obtained are not within the expected range of the control, the assay results may be invalid.
- A representative standard curve is shown in Figure 7. This curve cannot be used to derive test results. Each laboratory must prepare a standard curve for each group of microwell strips assayed.

Figure 7

Representative standard curve for human sTNF-R (60 kDa) ELISA. Human sTNF-R (60 kDa) was diluted in serial 2-fold steps in Assay Buffer (1x). Do not use this standard curve to derive test results. A standard curve must be run for each group of microwell strips assayed.

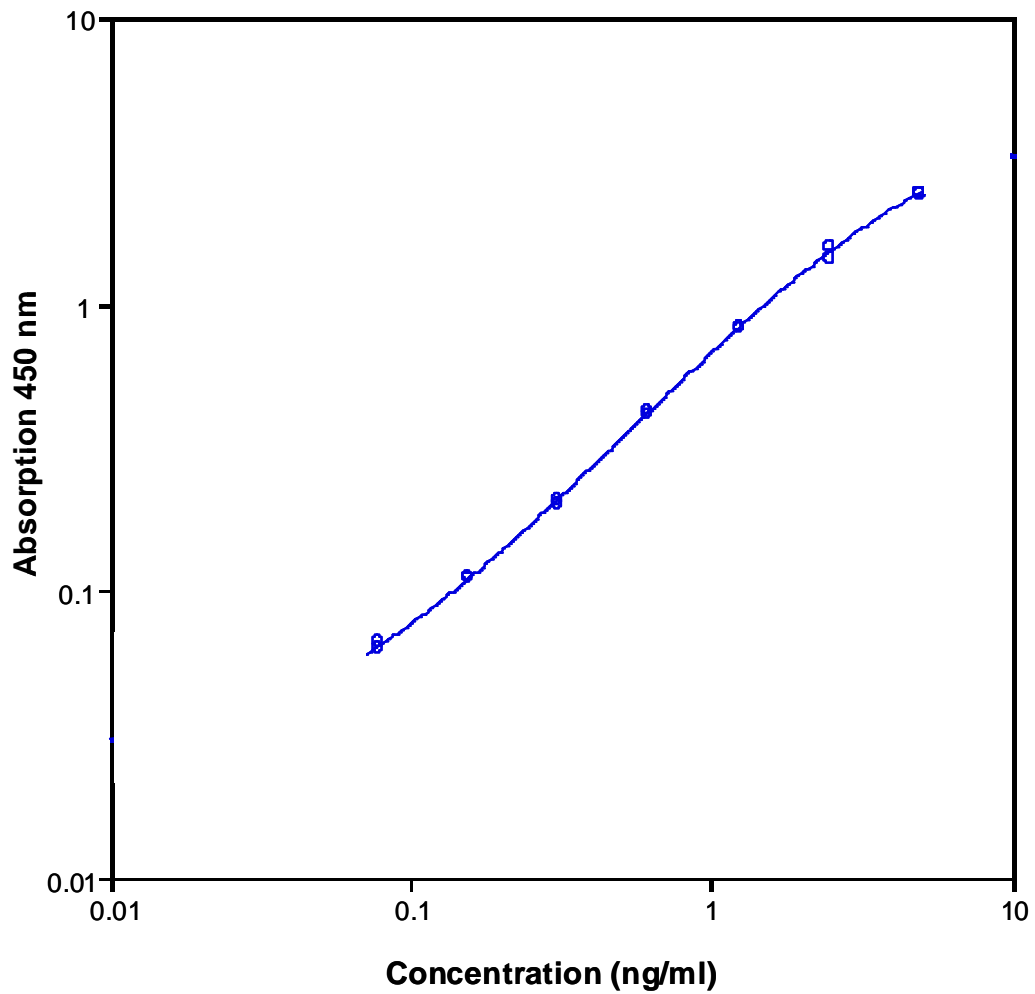

Table 2

Typical data using the human sTNF-R (60 kDa) ELISA

Measuring wavelength: 450 nm

Reference wavelength: 620 nm

Standard	Human sTNF-R (60 kDa) Concentration (ng/ml)	O.D. at 450 nm	Mean O.D. at 450 nm	C.V. (%)
1	5.00	2.413	2.425	0.5
	5.00	2.437		
2	2.50	1.431	1.510	5.2
	2.50	1.589		
3	1.25	0.820	0.827	0.9
	1.25	0.834		
4	0.63	0.414	0.419	1.2
	0.63	0.424		
5	0.31	0.201	0.205	1.6
	0.31	0.208		
6	0.16	0.112	0.111	0.7
	0.16	0.110		
7	0.08	0.063	0.065	2.9
	0.08	0.066		
Blank	0	0.016	0.017	
	0	0.017		

The OD values of the standard curve may vary according to the conditions of assay performance (e.g. operator, pipetting technique, washing technique or temperature effects). Furthermore shelf life of the kit may affect enzymatic activity and thus colour intensity. Values measured are still valid.

12 LIMITATIONS

- Since exact conditions may vary from assay to assay, a standard curve must be established for every run.
- Bacterial or fungal contamination of either screen samples or reagents or cross-contamination between reagents may cause erroneous results.
- Disposable pipette tips, flasks or glassware are preferred, reusable glassware must be washed and thoroughly rinsed of all detergents before use.
- Improper or insufficient washing at any stage of the procedure will result in either false positive or false negative results. Empty wells completely before dispensing fresh wash solution, fill with Wash Buffer as indicated for each wash cycle and do not allow wells to sit uncovered or dry for extended periods.
- The use of radioimmunotherapy has significantly increased the number of patients with human anti-mouse IgG antibodies (HAMA). HAMA may interfere with assays utilizing murine monoclonal antibodies leading to both false positive and false negative results. Serum samples containing antibodies to murine immunoglobulins can still be analysed in such assays when murine immunoglobulins (serum, ascitic fluid, or monoclonal antibodies of irrelevant specificity) are added to the sample.

13 PERFORMANCE CHARACTERISTICS

13.1 Sensitivity

The limit of detection of human sTNF-R (60 kDa) defined as the analyte concentration resulting in an absorbance significantly higher than that of the dilution medium (mean plus 2 standard deviations) was determined to be 0.05 ng/ml (mean of 6 independent assays).

13.2 Reproducibility

13.2.1 Intra-assay

Reproducibility within the assay was evaluated in 3 independent experiments. Each assay was carried out with 6 replicates of 8 serum samples containing different concentrations of human sTNF-R (60 kDa). 2 standard curves were run on each plate. Data below show the mean human sTNF-R (60 kDa) concentration and the coefficient of variation for each sample (see Table 3). The calculated overall intra-assay coefficient of variation was 1.9%.

Table 3

The mean human sTNF-R (60 kDa) concentration and the coefficient of variation for each sample

Sample	Experiment	Mean Human sTNF-R (60 kDa) Concentration (ng/ml)	Coefficient of Variation (%)
1	1	--	--
	2	1.57	0.9
	3	1.46	5.3
2	1	5.13	3.3
	2	5.84	1.7
	3	6.07	2.0
3	1	6.43	2.2
	2	6.45	1.0
	3	7.90	4.0
4	1	7.43	2.3
	2	7.60	1.2
	3	9.12	2.5
5	1	10.09	2.0
	2	9.87	1.2
	3	11.81	2.2
6	1	10.48	0.8
	2	10.86	0.4
	3	12.25	2.2
7	1	12.82	1.2
	2	12.83	0.4
	3	15.42	1.1
8	1	18.54	2.3
	2	17.30	0.8
	3	22.22	2.6

13.2.2 Inter-assay

Assay to assay reproducibility within one laboratory was evaluated in 3 independent experiments. Each assay was carried out with 6 replicates of 8 serum samples containing different concentrations of human sTNF-R (60 kDa). 2 standard curves were run on each plate. Data below show the mean human sTNF-R (60 kDa) concentration and the coefficient of variation calculated on 18 determinations of each sample (see Table 4). The calculated overall inter-assay coefficient of variation was 8.6%.

Table 4

The mean human sTNF-R (60 kDa) concentration and the coefficient of variation of each sample

Sample	Mean Human sTNF-R (60 kDa) Concentration (ng/ml)	Coefficient of Variation (%)
1	1.52	5.0
2	5.68	7.5
3	6.92	10.1
4	8.05	9.7
5	10.59	8.4
6	11.28	7.9
7	13.69	9.0
8	19.35	11.0

13.3 Spiking Recovery

The spiking recovery was evaluated by spiking 2 levels of human sTNF-R (60 kDa) into pooled normal serum diluted 1:10. Recoveries were determined in 3 independent experiments with 8 replicates each.

The amount of endogenous human sTNF-R (60 kDa) in unspiked serum was subtracted from the spike values.

The recovery ranged from 91% to 96% with an overall mean recovery of 93%.

13.4 Dilution Linearity

3 serum samples with different levels of human sTNF-R (60 kDa) were analysed at serial 2 fold dilutions with 4 replicates each.

The recovery ranged from 92% to 111% with an overall recovery of 103% (see Table 5).

Table 5

Sample	Dilution	Expected Human sTNF-R (60 kDa) Concentration (ng/ml)	Observed Human sTNF-R (60 kDa) Concentration (ng/ml)	Recovery of Expected Human sTNF-R (60 kDa) Concentration (%)
1	1:5	--	2.21	--
	1:10	1.11	1.12	100.9
	1:20	0.55	0.60	109.9
	1:40	0.28	0.31	110.7
2	1:5	--	21.99	--
	1:10	11.00	11.58	105.2
	1:20	5.50	5.53	100.6
	1:40	2.75	2.53	91.8
3	1:5	--	50.51	--
	1:10	25.26	27.27	107.8
	1:20	12.63	13.09	103.6
	1:40	6.31	6.18	97.9

13.5 Sample Stability

13.5.1 Freeze-Thaw Stability

Aliquots of serum samples (spiked or unspiked) were stored at -20°C and thawed 5 times, and the human sTNF-R (60 kDa) levels determined. There was no significant loss of human sTNF-R (60 kDa) immunoreactivity detected by freezing and thawing.

13.5.2 Storage Stability

Aliquots of serum samples (spiked or unspiked) were stored at -20°C, 2-8°C, room temperature (RT) and at 37°C, and the human sTNF-R (60 kDa) level determined after 24 h. There was no significant loss of human sTNF-R (60 kDa) immunoreactivity detected during storage under above conditions.

13.6 Comparison of Serum and Plasma

From 2 individuals, serum as well as EDTA, citrate and heparin plasma obtained at the same time point were evaluated. Human sTNF-R (60 kDa) concentrations were not significantly different and therefore all these body fluids are suitable for the assay (see Table 6)

Table 6

Sample	Human sTNF-R (60 kDa) Concentration (ng/ml)	
	Donor 1	Donor 2
Serum	1.72	1.79
EDTA Plasma	1.97	1.84
Citrate Plasma	1.55	1.77
Heparin Plasma	1.91	1.87

13.7 Specificity

The interference of circulating factors of the immune system was evaluated by spiking these proteins at physiologically relevant concentrations into a human sTNF-R (60 kDa) positive serum (50% calf serum containing 5 ng/ml TNF-R (60 kDa)).

There was no crossreactivity detected with human TNF α (< 10 ng/ml) and TNF β (< 100 μ g/ml).

13.8 Expected Values

A panel of 37 sera samples from randomly selected apparently healthy donors (males and females) was tested for human sTNF-R (60 kDa).

The detected human sTNF-R (60 kDa) levels ranged between 1.47 and 4.16 ng/ml with a mean level of 2.67 ng/ml and a standard deviation of 0.69 ng/ml.

14 REFERENCES

- 1) Adolf, G.R., and I. Apfler. (1991). A monoclonal antibody-based enzyme immunoassay for quantitation of human tumor necrosis factor binding protein I, a soluble fragment of the 60 kDa TNF receptor in biological fluids. *J. Immunol. Meth.* 143, 127 - 136.
- 2) Aggarwal, B.B., T.E. Eessalu, and P.E. Hass. (1985). Characterization of receptors for human tumour necrosis factor and their regulation by gamma-interferon. *Nature* 318, 665 - 667.
- 3) Aggarwal, B.B. (1987). Tumor necrosis Factor - TNF- α and TNF- β : their structure pleiotropic biological effects. *Drugs Future* 12, 891 - 898.
- 4) Baglioni, C., S. McCandless, J. Tavernier, and W. Fiers (1985). Binding of human tumor necrosis factor to high affinity receptors on HeLa and lymphoblastoid cells sensitive to growth inhibition. *J. Biol. Chem.* 260, 13395 - 13397.
- 5) Beutler, B., J. Mahoney, N. Le Trang, P. Pekala, and A. Cerami. (1985). Purification of cachectin, a lipoprotein lipase-suppressing hormone secreted by endotoxin-induced RAW 264.7 cells. *J. Exp. Med.* 161, 984 - 995.
- 6) Beutler, B., and A. Cerami. (1987). Cachectin: more than a tumor necrosis factor. *N. Eng. J. Med.* 316, 379 - 385.
- 7) Brockhaus, M., H.J. Schoenfeld, E.J. Schlaeger, W. Hunziker, W. Lesslauer, and H. Loetscher. (1990). Identification of two types of tumor necrosis factor receptors on human cell lines by monoclonal antibodies. *Proc. Natl. Acad. Sci. USA* 87, 3127 - 3131.
- 8) Carswell, E.A., L.J. Old, R.L. Kassel, S. Green, N. Fiore, and B. Williamson. (1975). An endotoxin-induced serum factor that causes necrosis of tumors. *Proc. Natl. Acad. Sci. USA* 72, 3666 - 3670.
- 9) Creasey, A.A., R. Yamamoto, and C.R. Vitt. (1987). A high molecular weight component of the human tumor necrosis factor receptor is associated with cytotoxicity. *Proc. Natl. Acad. Sci. USA* 84, 3293 - 3297.

- 10) Himmler, A., I. Maurer-Fogy, M. Krönke, P. Scheurich, K. Pfizenmaier, M. Lantz, I. Olsson, R. Hauptmann, C. Stratowa, and G.R. Adolf. (1990). Molecular cloning and expression of human and rat tumor necrosis factor receptor chain (p60) and its soluble derivative, tumor necrosis factor-binding protein. *DNA and Cell Biology* 10, 705 - 715.
- 11) Hohmann, H.P., R. Remy, M. Brockhaus, and A.P.G.M. van Loon. (1989). Two different cell types have different major receptors for human tumor necrosis factor (TNF- α). *J. Biol. Chem.* 264, 14927 - 14934.
- 12) Kull, F.C., S. Jacobs, and P. Cuatrecasas. (1985). Cellular receptor for 125I-labeled tumor necrosis factor: specific binding, affinity labeling, and relationship to sensitivity. *Proc. Natl. Acad. Sci. USA* 82, 5756 - 5760.
- 13) Loetscher, H., Y.E. Pan, H.-W. Lahm, R. Gentz, M. Brockhaus, H. Tabuchi, and W. Lesslauer. (1990). Molecular Cloning and Expression of the Human 55 kd Tumor Necrosis Factor Receptor. *Cell* 61, 351 - 359.
- 14) Munker, R., J. DiPersio, and H.P. Koeffler. (1987). Tumor Necrosis Factor: Receptors on Hematopoietic Cells. *Blood* 70, 1730 - 1734.
- 15) Old L. (1985). Tumor necrosis factor (TNF). *Science* 230, 630 - 632.
- 16) Olsson I., M. Lantz, E. Nilsson, C. Peetre, H. Thyssel, A. Grubb, and G. Adolf. (1989). Isolation and characterization of a tumor necrosis factor binding protein from urine. *Eur. J. Haematol.* 42, 270 - 275.
- 17) Paul N., and N. Ruddle. (1988). Lymphotoxin. *Ann. Rev. Immunol.* 6, 407 - 438.
- 18) Rubin B., S. Anderson, S. Sullivan, B. Williamson, E. Carswell, and L. Old. (1985). High affinity binding of 125I-labeled human tumor necrosis factor (LuKII) to specific cell surface receptors. *J. Exp. Med.* 162, 1099 - 1104.

- 19) Schall T., M. Lewis, K.J. Koller, A. Lee, G.C. Rice, G.H.W. Wong, T. Gatanaga, G.A. Granger, R. Lentz, H. Raab, W. J. Kohr, and D.V. Goeddel. (1990). Molecular cloning and expression of a receptor for human tumor necrosis factor. *Cell* 61, 361 - 370.
- 20) Scheurich, P., U. Ücer, M. Krönke, and K. Pfizenmaier. (1986). Quantification and characterization of high-affinity membrane receptors for tumor necrosis factor on human leukemic cell lines. *Int. J. Cancer* 38, 127 - 133.
- 21) Scheurich, P., B. Thoma, U. Ücer, and K. Pfizenmaier. (1987). Immunoregulatory activity of recombinant human tumor necrosis factor (TNF)- α : Induction of TNF receptors on human T cells and TNF- α mediated enhancement of T cell responses. *J. Immunol.* 138, 1786 - 1790.
- 22) Smith, C.A., T. Davis, D. Anderson, L. Solam, M.P. Beckmann, R. Jerzy, S.K. Dower, D. Cosman, and R.G. Goodwin. (1990). A receptor for tumor necrosis factor defines an unusual family of cellular and viral proteins. *Science* 248, 1019 - 1023.
- 23) Sprang, S.R. (1990). The divergent receptors for TNF. *TIBS* 15, 366 - 368.
- 24) Thoma, B., M. Grell, K. Pfizenmaier, and P. Scheurich. (1990). Identification of a 60-kD tumor necrosis factor (TNF) receptor as the major signal transducing component in TNF responses. *J. Exp. Med.* 172, 1019 - 1023.
- 25) Tsujimoto, M., Y.K. Yip, and J. Vilcek. (1985). Tumor necrosis factor: Specific binding and internalization in sensitive and resistant cells. *Proc. Natl. Acad. Sci. USA* 82, 7626 - 7630.

15 REAGENT PREPARATION SUMMARY

15.1 Wash Buffer

Add **Wash Buffer Concentrate 20x** (50 ml) to 950 ml distilled water.

Number of Strips	Wash Buffer Concentrate (ml)	Distilled Water (ml)
1 - 6	25	475
1 - 12	50	950

15.2 Assay Buffer (1x)

Add **Assay Buffer Concentrate 20x** (5 ml) to 95 ml distilled water.

Number of Strips	Assay Buffer Concentrate (ml)	Distilled Water (ml)
1 - 6	2.5	47.5
1 - 12	5.0	95.0

15.3 HRP-Conjugate

Make a 1:100 dilution of **HRP-Conjugate** in Assay Buffer (1x):

Number of Strips	HRP-Conjugate (ml)	Assay Buffer (1x) (ml)
1 - 6	0.03	2.97
1 - 12	0.06	5.94

15.4 Human sTNF-R (60 kDa) Standard

Prepare **human sTNF-R (60 kDa) standard** by addition of Assay Buffer (1x) as stated on the label and swirl or mix gently.

15.5 Control

Add 100 µl distilled water to lyophilized **control**.

16 TEST PROTOCOL SUMMARY

1. Determine the number of microwell strips required.
2. Wash microwell strips twice with Wash Buffer.
3. Standard dilution on the microwell plate: Add 100 µl Assay Buffer (1x), in duplicate, to all standard wells. Pipette 100 µl prepared standard into the first wells and create standard dilutions by transferring 100 µl from well to well. Discard 100 µl from the last wells.
Alternatively external standard dilution in tubes (see 9.4.1): Pipette 100 µl of these standard dilutions in the microwell strips.
4. Add 100 µl Assay Buffer (1x), in duplicate, to the blank wells.
5. Add 90 µl Assay Buffer (1x) to sample wells.
6. Add 10 µl sample in duplicate, to designated sample wells.
7. Prepare HRP-Conjugate.
8. Add 50 µl (100 µl for urine samples) HRP-Conjugate to all wells.
9. Cover microwell strips and incubate 2 hours at room temperature (18° to 25°C).
10. Empty and wash microwell strips 3 times with Wash Buffer.
11. Add 100 µl of TMB Substrate Solution to all wells.
12. Incubate the microwell strips for about 10 minutes at room temperature (18° to 25°C).
13. Add 100 µl Stop Solution to all wells.
14. Blank microwell reader and measure colour intensity at 450 nm.

Note: If instructions in this protocol have been followed samples have been diluted 1:10 (10 µl sample + 90 µl Assay Buffer (1x)), the concentration read from the standard curve must be multiplied by the dilution factor (x 10).

NOTES



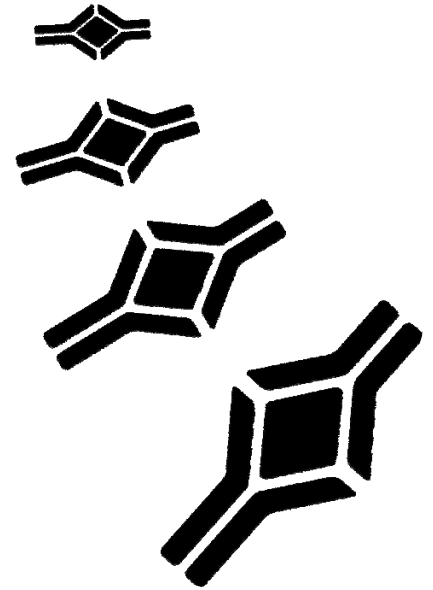

HEADQUARTERS: BioVendor Laboratorní medicina, a.s.	CTPark Modrice Evropska 873	664 42 Modrice CZECH REPUBLIC	Phone: +420-549-124-185 Fax: +420-549-211-460	E-mail: info@biovendor.com Web: www.biovendor.com
EUROPEAN UNION: BioVendor GmbH	Im Neuenheimer Feld 583	D-69120 Heidelberg GERMANY	Phone: +49-6221-433-9100 Fax: +49-6221-433-9111	E-mail: infoEU@biovendor.com
USA, CANADA AND MEXICO: BioVendor LLC	1463 Sand Hill Road Suite 227	Candler, NC 28715 USA	Phone: +1-828-670-7807 +1-800-404-7807 Fax: +1-828-670-7809	E-mail: infoUSA@biovendor.com
CHINA - Hong Kong Office: BioVendor Laboratories Ltd	Room 4008 Hong Kong Plaza, No.188	Connaught Road West Hong Kong, CHINA	Phone: +852-2803-0523 Fax: +852-2803-0525	E-mail: infoHK@biovendor.com
CHINA – Mainland Office: BioVendor Laboratories Ltd	Room 2405 YiYa Tower TianYu Garden, No.150	Lihe Zhong Road Guang Zhou, CHINA	Phone: +86-20-8706-3029 Fax: +86-20-8706-3016	E-mail: infoCN@biovendor.com