

BioVendor

Research
and Diagnostic Products

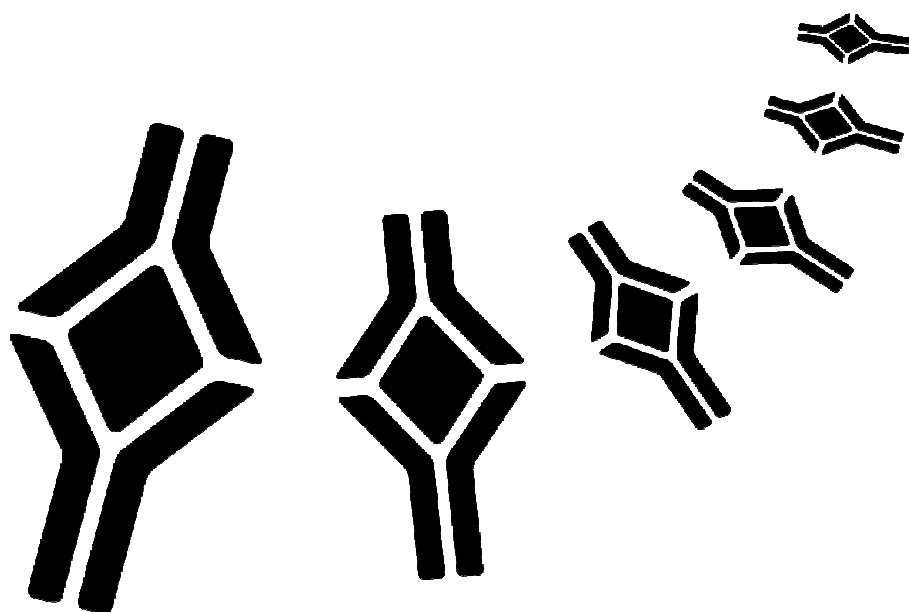

Monkey INTERLEUKIN-10 ELISA

Product Data Sheet

Cat. No.: RBMS642/2R

For Research Use Only

CONTENTS

1	INTENDED USE	3
2	SUMMARY	3
3	PRINCIPLES OF THE TEST	4
4	REAGENTS PROVIDED	5
5	STORAGE INSTRUCTIONS – ELISA KIT	5
6	SPECIMEN COLLECTION AND STORAGE INSTRUCTIONS	5
7	MATERIALS REQUIRED BUT NOT PROVIDED	6
8	PRECAUTIONS FOR USE	6
9	PREPARATION OF REAGENTS	7
10	TEST PROTOCOL	10
11	CALCULATION OF RESULTS	13
12	LIMITATIONS	16
13	PERFORMANCE CHARACTERISTICS	16
14	REFERENCES	18
15	REAGENT PREPARATION SUMMARY	18
16	TEST PROTOCOL SUMMARY	19

➤➤ This kit is manufactured by:
BioVendor – Laboratorní medicína, a.s.

➤➤ Use only the current version of Product Data Sheet enclosed with the kit!

1 INTENDED USE

The monkey IL-10 ELISA is an enzyme-linked immunosorbent assay for quantitative detection of monkey Interleukin-10 in cell culture supernatants, monkey serum, plasma or other body fluids. **The monkey IL-10 ELISA is for research use only. Not for use in diagnostic or therapeutic procedures.**

2 SUMMARY

Interleukin-10 is a pleiotropic cytokine playing an important role as a regulator of lymphoid and myeloid cell function. Due to the ability of IL-10 to block cytokine synthesis and several accessory cell functions of macrophages this cytokine is a potent suppressor of the effector functions of macrophages, T-cells and NK cells. In addition, IL-10 participates in regulating proliferation and differentiation of B-cells, mast cells and thymocytes (1).

3 PRINCIPLES OF THE TEST

An anti-monkey-IL-10 monoclonal coating antibody is adsorbed onto microwells.

Monkey IL-10 present in the sample or standard binds to antibodies adsorbed to the microwells; a biotin conjugated monoclonal anti-monkey-IL-10 antibody is added and binds to monkey IL-10 captured by the first antibody.

Following incubation unbound biotin conjugated anti-monkey IL-10 is removed during a wash step. Streptavidin-HRP is added and binds to the biotin conjugated anti-monkey-IL-10. Following incubation unbound Streptavidin-HRP is removed during a wash step, and substrate solution reactive with HRP is added to the wells.

A coloured product is formed in proportion to the amount of monkey IL-10 present in the sample. The reaction is terminated by addition of acid and absorbance is measured at 450 nm. A standard curve is prepared from seven monkey IL-10 standard dilutions and monkey IL-10 sample concentration determined.

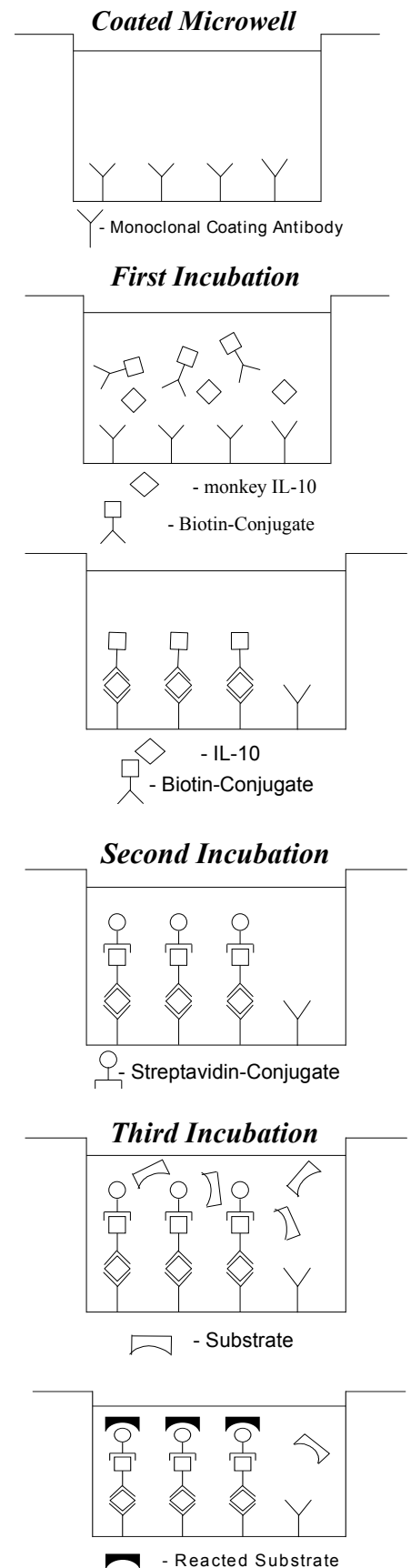

4 REAGENTS PROVIDED

- 1 aluminium pouch with a **Antibody Coated Microtiter Strips** (murine) to monkey IL-10
 - 1 vial (100 µl) **Biotin-Conjugate** anti-monkey-IL-10 monoclonal (murine) antibody)
 - 1 vial (150 µl) **Streptavidin-HRP**
 - 2 vials **monkey IL-10 Standard**, lyophilized; 500U/ml upon reconstitution
 - 1 bottle (50 ml) **Wash Buffer Concentrate** 20x (PBS with 1% Tween 20)
 - 1 vial (5 ml) **Assay Buffer Concentrate** 20x (PBS with 1% Tween 20 and 10% BSA)
 - 1 vial (15 ml) **Substrate Solution**
 - 1 vial (12 ml) **Stop Solution** (1M Phosphoric acid)
 - 1 vial (0.4 ml each) **Blue-Dye, Green-Dye, Red-Dye**
 - 4 adhesive **Plate Covers**
- Reagent Labels**

5 STORAGE INSTRUCTIONS – ELISA KIT

Store kit reagents between 2° and 8°C. Immediately after use remaining reagents should be returned to cold storage (2° to 8°C). Expiry of the kit and reagents is stated on labels.

The expiry of the kit components can only be guaranteed if the components are stored properly, and if, in case of repeated use of one component, the reagent is not contaminated by the first handling.

6 SPECIMEN COLLECTION AND STORAGE INSTRUCTIONS

Cell culture supernatants, monkey serum, plasma, urine or other biological samples will be suitable for use in the assay. Remove serum from the clot or red cells, respectively, as soon as possible after clotting and separation.

Samples containing a visible precipitate must be clarified prior to use in the assay. Do not use grossly hemolyzed or lipemic specimens.

Clinical samples should be kept at 2° to 8°C and separated rapidly before storing at -20°C to avoid loss of bioactive monkey IL-10. If samples are to be run within 24 hours, they may be stored at 2° to 8°C. Avoid repeated freeze-thaw cycles.

For stability of samples refer to 13. E.

7 MATERIALS REQUIRED BUT NOT PROVIDED

- 5 ml and 10 ml graduated pipettes
- 10 μ l to 1,000 μ l adjustable single channel micropipettes with disposable tips
- 50 μ l to 300 μ l adjustable multichannel micropipette with disposable tips
- Multichannel micropipette reservoir
- Beakers, flasks, cylinders necessary for preparation of reagents
- Device for delivery of wash solution (multichannel wash bottle or automatic wash system)
- Microwell strip reader capable of reading at 450 nm (620 nm as optional reference wave length)
- Glass-distilled or deionized water
- Statistical calculator with program to perform linear regression analysis.

8 PRECAUTIONS FOR USE

- All chemicals should be considered as potentially hazardous. We therefore recommend that this product is handled only by those persons who have been trained in laboratory techniques and that it is used in accordance with the principles of good laboratory practice. Wear suitable protective clothing such as laboratory overalls, safety glasses and gloves. Care should be taken to avoid contact with skin or eyes. In the case of contact with skin or eyes wash immediately with water. See material safety data sheet(s) and/or safety statements(s) for specific advice.
- Reagents are intended for research use only and are not for use in diagnostic or therapeutic procedures.
- Do not mix or substitute reagents with those from other lots or other sources.
- Do not use kit reagents beyond expiration date on label.
- Do not expose kit reagents to strong light during storage or incubation.
- Do not pipette by mouth.
- Do not eat or smoke in areas where kit reagents or samples are handled.
- Avoid contact of skin or mucous membranes with kit reagents or specimens.
- Rubber or disposable latex gloves should be worn while handling kit reagents or specimens.
- Avoid contact of substrate solution with oxidizing agents and metal.
- Avoid splashing or generation of aerosols.
- In order to avoid microbial contamination or cross-contamination of reagents or specimens which may invalidate the test use disposable pipette tips and/or pipettes.
- Use clean, dedicated reagent trays for dispensing the conjugate and substrate reagents.

- Exposure to acids will inactivate the conjugate.
- Glass-distilled water or deionized water must be used for reagent preparation.
- Substrate solution must be at room temperature prior to use.
- Decontaminate and dispose specimens and all potentially contaminated materials as if they could contain infectious agents. The preferred method of decontamination is autoclaving for a minimum of 1 hour at 121.5°C.
- Liquid wastes not containing acid and neutralized waste may be mixed with sodium hypochlorite in volumes such that the final mixture contains 1.0% sodium hypochlorite. Allow 30 minutes for effective decontamination. Liquid waste containing acid must be neutralized prior to the addition of sodium hypochlorite.

9 PREPARATION OF REAGENTS

Wash Buffer (reagent A.) and Assay Buffer (reagent B.) should be prepared before starting with the test procedure.

A. Wash Buffer

If crystals have formed in the Wash Buffer Concentrate, warm it gently until they have completely dissolved.

Pour entire contents (50 ml) of the **Wash Buffer Concentrate** into a clean 1,000 ml graduated cylinder. Bring final volume to 1,000 ml with glass-distilled or deionized water. Mix gently to avoid foaming. The pH of the final solution should adjust to 7.4.

Transfer to a clean wash bottle and store at 2° to 25°C. Please note that the Wash Buffer is stable for 30 days. Wash Buffer may be prepared as needed according to the following table:

Number of Strips	Wash Buffer Concentrate (ml)	Distilled Water (ml)
1 - 6	25	475
1 - 12	50	950

B. Assay Buffer

Mix the contents of the bottle well. Add contents of **Assay Buffer Concentrate** (5.0 ml) to 95 ml distilled or deionized water and mix gently to avoid foaming. Store at 2° to 8°C. Please note that the Assay Buffer is stable for 30 days. Assay Buffer may be prepared as needed according to the following table:

Number of Strips	Assay Buffer Concentrate (ml)	Distilled Water (ml)
1 - 6	2.5	47.5
1 - 12	5.0	95.0

C. Preparation of Biotin-Conjugate

Make a 1:100 dilution of the **Biotin-Conjugate** with Assay Buffer (reagent B) in a clean plastic tube.

Please note that the Biotin-Conjugate should be used within 30 minutes after predilution. The Biotin-Conjugate may be prepared as needed according to the following table:

Number of Strips	Biotin-Conjugate (ml)	Assay Buffer (ml)
1 - 6	0.03	2.97
1 - 12	0.06	5.94

D. Preparation of Streptavidin-HRP

Make a 1:100 dilution of the concentrated **Streptavidin-HRP** solution in **Assay Buffer** as needed according to the following table:

Number of Strips	Streptavidin-HRP (ml)	Assay Buffer (ml)
1 - 6	0.06	6
1 - 12	0.12	12

E. Preparation of monkey IL-10 Standard

Reconstitute **monkey IL-10 Standard** by addition of distilled water. Refer to the Certificate of Analysis for current volume of Distilled water needed for reconstitution of standard.

Swirl or mix gently to insure complete and homogeneous solubilization.

F. Addition of colour-giving reagents: Blue-Dye, Green-Dye, Red-Dye

This procedure is optional, does not in any way interfere with the test results, and is designed to help the customer with the performance of the test, but can also be omitted, just following the instruction booklet.

Alternatively, the dye solutions from the stocks provided (**Blue-Dye**, **Green-Dye**, **Red-Dye**) can be added to the reagents according to the following guidelines:

1. Diluent:

Before sample dilution add the **Blue-Dye** at a dilution of 1:250 (see table below) to the appropriate diluent (1x) according to the test protocol. After addition of **Blue-Dye**, proceed according to the instruction booklet.

5 ml Assay Buffer	20 µl Blue-Dye
12 ml Assay Buffer	48 µl Blue-Dye

2. Biotin-Conjugate:

Before dilution of the concentrated conjugate, add the **Green-Dye** at a dilution of 1:100 (see table below) to the Assay Buffer used for the final conjugate dilution. Proceed after addition of **Green-Dye** according to the instruction booklet, preparation of Biotin-conjugate.

3 ml Assay Buffer	30 µl Green-Dye
6 ml Assay Buffer	60 µl Green-Dye
12 ml Assay Buffer	120 µl Green-Dye

3. Streptavidin-HRP:

Before dilution of the concentrated Streptavidin-HRP; add the Red-Dye at a dilution of 1:250 (see table below) to the Assay Buffer used for the final Streptavidin-HRP dilution. Proceed after addition of Red-Dye according to the instruction booklet, preparation of Streptavidin-HRP.

6 ml Assay Buffer	24 µl Red-Dye
12 ml Assay Buffer	48 µl Red-Dye

10 TEST PROTOCOL

- a. Mix all reagents thoroughly without foaming prior to use.
- b. Determine the number of Microwell Strips required to test the desired number of samples plus appropriate number of wells needed for running blanks and standards. Each sample, standard, blank and optional control sample should be assayed in duplicate. Remove extra **Microwell Strips coated with Monoclonal Antibody** (murine) to monkey IL-10 from holder and store in foil bag with the desiccant provided at 2°-8°C sealed tightly.
- c. Wash the microwell strips twice with approximately 300 µl **Wash Buffer** per well with thorough aspiration of microwell contents between washes. Take care not to scratch the surface of the microwells.
After the last wash, empty wells and tap microwell strips on absorbent pad or paper towel to remove excess Wash Buffer. Use the microwell strips immediately after washing or place upside down on a wet absorbent paper for not longer than 15 minutes. Do not allow wells to dry.
- d. Add 100 µl of **Assay Buffer** in duplicate to all standard wells. Prepare standard dilutions by pipetting 100 µl of solubilized **monkey IL-10 Standard** (Refer to preparation of reagents, 9.E.), in duplicate, into well A1 and A2 (see Figure 1 and 2). Mix the contents of wells A1 and A2 by repeated aspiration and ejection, and transfer 100 µl to well B1 and B2, respectively. Take care not to scratch the inner surface of the microwells. Continue this procedure five times, creating two rows of monkey IL-10 Standard dilutions ranging from 250 to 3.9 U/ml. Discard 100 µl of the contents from the last microwells (G1, G2) used.

Figure 1. Preparation of monkey IL-10 standard dilutions:

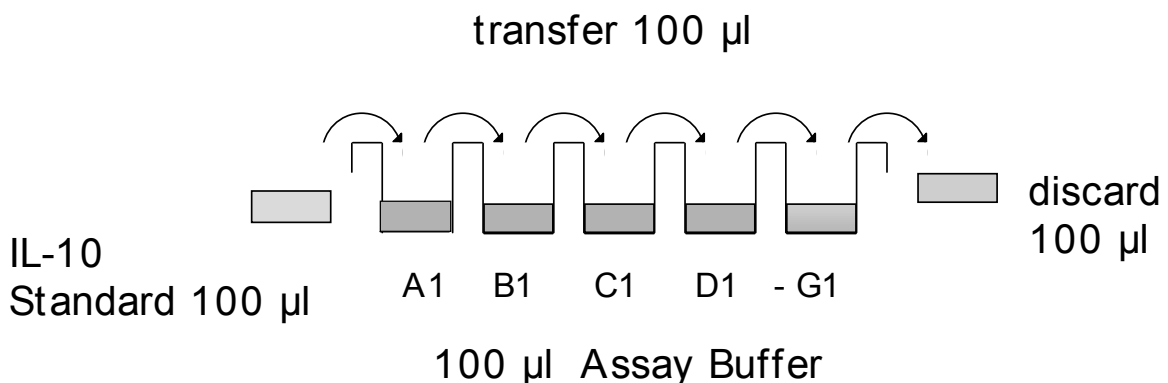

Figure 2. Diagram depicting an example of the arrangement of blanks, standards and samples in the microwell strips:

	1	2	3	4
A	Standard 1 (250 U/ml)	Standard 1 (250 U/ml)	Sample 1	Sample 1
B	Standard 2 (125 U/ml)	Standard 2 (125 U/ml)	Sample 2	Sample 2
C	Standard 3 (63 U/ml)	Standard 3 (63 U/ml)	Sample 3	Sample 3
D	Standard 4 (32 U/ml)	Standard 4 (32 U/ml)	Sample 4	Sample 4
E	Standard 5 (16 U/ml)	Standard 5 (16 U/ml)	Sample 5	Sample 5
F	Standard 6	Standard 6 (8 U/ml)	Sample 6 (8 U/ml)	Sample 6
G	Standard 7	Standard 7 (4 U/ml)	Sample 7 (4 U/ml)	Sample 7
H	Blank	Blank	Sample 8	Sample 8

- e. Add 100 µl of **Assay Buffer** in duplicate to the blank wells.
- f. Add 50 µl **Assay Buffer** to all wells designated for samples.
- g. Add 50 µl of each **Sample**, in duplicate, to the designated wells and mix the contents.
- h. Prepare **Biotin-Conjugate**. (Refer to preparation of reagents 9.C.)
- i. Add 50 µl of diluted **Biotin-Conjugate** to all wells, including the blank wells.
- j. Cover with a **Plate Cover** and incubate at room temperature (18° to 25°C) for 2 hours, if available on a rotator set at 100 rpm.
- k. Prepare **Streptavidin-HRP** (refer to preparation of reagents 9.D).
- l. Remove Plate Cover and empty wells. Wash microwell strips 3 times according to point c. of the test protocol. Proceed immediately to the next step.
- m. Add 100 µl of diluted **Streptavidin-HRP** to all wells, including the blank wells.
- n. Cover with a **Plate Cover** and incubate at room temperature (18° to 25°C) for 1 hour on a microplate shaker at 200 rpm.
- o. Remove Plate Cover and empty wells. Wash microwell strips 3 times according to point c. of the test protocol. Proceed immediately to the next step.
- p. Pipette 100 µl of **TMB Substrate Solution** to all wells, including the blank wells.
- q. Incubate the microwell strips at room temperature (18° to 25°C) for about 10 minutes. Avoid direct exposure to intense light.

The colour development on the plate should be monitored and the substrate reaction stopped (see point r. of this protocol) before positive wells are no longer properly recordable.

It is recommended to add the stop solution when the highest standard has developed a dark blue colour.

Alternatively the colour development can be monitored by the ELISA reader at 620 nm. The substrate reaction should be stopped as soon as an OD of 0.6 – 0.65 is reached.

- r. Stop the enzyme reaction by quickly pipetting 100 µl of **Stop Solution** into each well, including the blank wells. It is important that the Stop Solution is spread quickly and uniformly throughout the microwells to completely inactivate the enzyme. Results must be read immediately after the Stop Solution is added or within one hour if the microwell strips are stored at 2 - 8°C in the dark.
- s. Read absorbance of each microwell on a spectro-photometer using 450 nm as the primary wave length (optionally 620 nm as the reference wave length; 610 nm to 650 nm is acceptable). Blank the plate reader according to the manufacturer's instructions by using the blank wells. Determine the absorbance of both, the samples and the monkey IL-10 standards.

Note: In case of incubation without shaking the obtained O.D. values may be lower than indicated below. Nevertheless the results are still valid.

11 CALCULATION OF RESULTS

- Calculate the average absorbance values for each set of duplicate standards and samples. Duplicates should be within 20 per cent of the mean.
- Create a standard curve by plotting the mean absorbance for each standard concentration on the ordinate against the monkey IL-10 concentration on the abscissa. Draw a best fit curve through the points of the graph.
- To determine the concentration of monkey IL-10 for each sample, first find the mean absorbance value on the ordinate and extend a horizontal line to the standard curve. At the point of intersection, extend a vertical line to the abscissa and read the corresponding monkey IL-10 concentration.
- **For samples which have been diluted according to the instructions given in this manual 1:2, the concentration read from the standard curve must be multiplied by the dilution factor (x2).**
- Note: Calculation of samples with an O.D. exceeding 2.0 may result in incorrect, low monkey IL-10 levels. Such samples require further dilution of 1:4 - 1:8 or even higher with Assay Buffer in order to precisely quantitate the actual monkey IL-10 level.
- It is suggested that each testing facility establishes a control sample of known monkey IL-10 concentration and runs this additional control with each assay. If the values obtained are not within the expected range of this control, the assay results may be invalid.
- A representative standard curve is shown in Figure 3. This curve cannot be used to derive test results. Every laboratory must prepare a standard curve for each group of microwell strips assayed.

Figure 3. Representative standard curve for the monkey IL-10 ELISA. Monkey IL-10 was diluted in serial two-fold steps in Assay Buffer, symbols represent the mean of three parallel titrations. Do not use this standard curve to derive test results. A standard curve must be run for each group of microwell strips assayed.

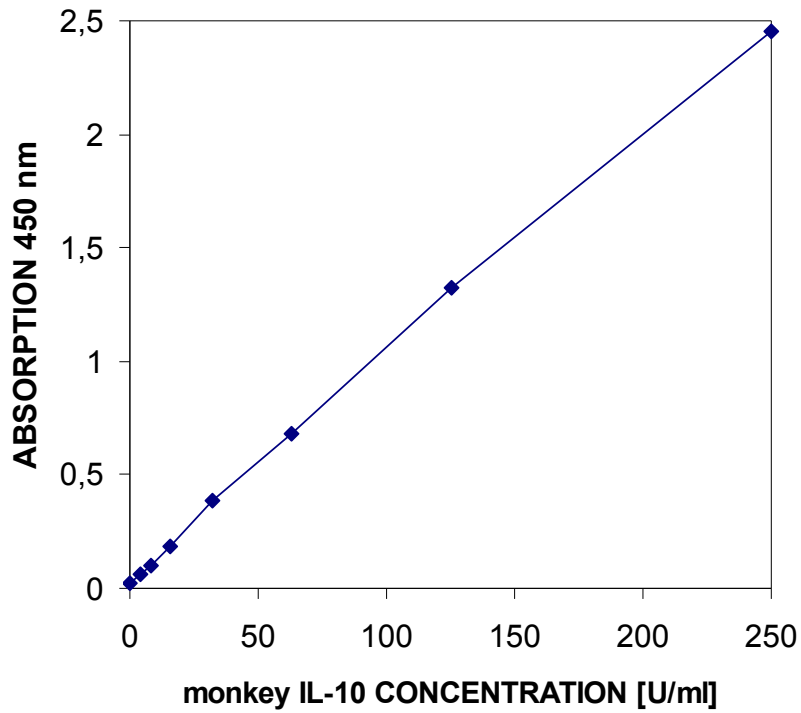

Typical data using the monkey IL-10 ELISA

Measuring wavelength: 450 nm

Reference wavelength: 620 nm

Standard	monkey IL-10 Concentration (U/ml)	O.D. Mean	C.V. (%)
1	250 250	2.450	4.2
2	125 125	1.325	5.1
3	63 63	0.680	6.2
4	32 32	0.385	1.8
5	16 16	0.183	2.0
6	8 8	0.103	5.4
7	4 4	0.065	6.1
Blank	0 0	0.025	

The OD values of the standard curve may vary according to the conditions of assay performance (e.g. temperature effects). Furthermore shelf life of the kit may effect enzymatic activity and thus colour intensity. Values measured are still valid.

12 LIMITATIONS

- Since exact conditions may vary from assay to assay, a standard curve must be established for every run.
- Bacterial or fungal contamination of either screen samples or reagents or cross-contamination between reagents may cause erroneous results.
- Disposable pipette tips, flasks or glassware are preferred, reusable glassware must be washed and thoroughly rinsed of all detergents before use.
- Improper or insufficient washing at any stage of the procedure will result in either false positive or false negative results. Completely empty wells before dispensing fresh Wash Buffer, fill with Wash Buffer as indicated for each wash cycle and do not allow wells to sit uncovered or dry for extended periods.

13 PERFORMANCE CHARACTERISTICS

A. Sensitivity

The limit of detection for monkey IL-10 defined as the analyte concentration resulting in an absorption significantly higher than that of the dilution medium (mean plus two standard deviations) was determined to be 1.32 U/ml (mean of 6 independent assays).

B. Reproducibility

a. Intra-assay

Reproducibility within the assay was evaluated in independent experiments. The overall Intra assay coefficient of variation has been calculated to be <5 %.

b. Inter-assay

Assay to assay reproducibility within one laboratory was evaluated in independent experiments by three technicians. The overall inter-assay coefficient of variation has been calculated to be <10 %.

C. Spiking Recovery

The spiking recovery was evaluated by spiking four levels of monkey IL-10 into pooled monkey serum. Recoveries were in mean 95 %.

D. Dilution Linearity

Four serum samples with different levels of IL-10 were assayed at serial two-fold dilutions (1:2 - 1:16). Recoveries were in mean 100 %.

E. Sample Stability

a. Freeze-Thaw Stability

Aliquots of serum samples (unspiked or spiked with monkey IL-10) were stored at -20°C and thawed and frozen several times, and the monkey IL-10 levels determined. There was a slight loss of monkey IL-10 by freezing and thawing for each cycle.

b. Storage Stability

Aliquots of a serum sample (spiked or unspiked with monkey IL-10) were stored at -20°C, 2-8°C, room temperature (RT) and at 37°C, and the monkey IL-10 level determined after 24 h. There was no significant loss of monkey IL-10 immunoreactivity during storage at -20°C, 2-8°C and room temperature, but notable loss of monkey IL-10 immunoreactivity was seen following storage at 37°C.

F. Specificity

The interference of circulating factors of the immune systems was evaluated by spiking these proteins at physiologically relevant concentrations into a monkey IL-10 positive serum. There was no detectable cross reactivity.

14 REFERENCES

- 1) Moore K. W., A. O'Garra, R. de Waal Malefyt, P. Vieira, and T. R. Mosmann. (1993). Interleukin-10. *Ann. Rev. Immunol.* 11, 165-190.

15 REAGENT PREPARATION SUMMARY

A. Wash Buffer Add **Wash Buffer Concentrate** 20 x (50 ml) to 950 ml distilled water

B. Assay Buffer	Number of Strips	Assay Buffer Concentr. (ml)	Distilled Water (ml)
	1 - 6	2.5	47.5
	1 - 12	5.0	95.0

C. Biotin-Conjugate Make a 1:100 dilution according to the table.

	Number of Strips	Biotin-Conjugate (ml)	Assay Buffer (ml)
	1 - 6	0.03	2.97
	1 - 12	0.06	5.94

D. Streptavidin-HRP Make a 1:100 dilution according to the table.

	Number of Strips	Streptavidin-HRP (ml)	Assay Buffer (ml)
	1 - 6	0.06	6.0
	1 - 12	0.12	12.0

E. monkey IL-10 Standard Reconstitute **monkey IL-10 Standard** by addition of distilled water. Reconstitution volume is stated on the label of the standard vial.

16 TEST PROTOCOL SUMMARY

- Wash microwell strips twice with **Wash Buffer**
- Add 100 µl Assay Buffer, in duplicate, to all standard wells
- Pipette 100 µl solubilized **monkey IL-10 Standard** into the first wells and create standard dilutions ranging from 250 to 4 U/ml by transferring 100 µl from well to well. Discard 100 µl from the last wells
- Add 100 µl **Assay Buffer**, in duplicate, to the blank wells
- Add 50 µl **Assay Buffer** to the sample wells
- Add 50 µl **Sample**, in duplicate, to designated wells
- Prepare **Biotin-Conjugate**
- Add 50 µl of diluted **Biotin-Conjugate** to all wells
- Cover microwell strips and incubate 2 hours at room temperature (18° to 25°C)
- Prepare **Streptavidin-HRP**
- Empty and wash microwell strips 3 times with Wash Buffer
- Add 100 µl of diluted **Streptavidin-HRP** to all wells.
- Cover microwell strips and incubate 1 hour at room temperature (18° to 25°C)
- Empty and wash microwell strips 3 times with **Wash Buffer**
- Add 100 µl of **TMB Substrate Solution** to all wells including blank wells
- Incubate the microwell strips for about 10 to 20 minutes at room temperature (18°to 25°C).
- Add 100 µl **Stop Solution** to all wells including blank wells
- Blank microwell reader and measure colour intensity at 450 nm

Note: For samples which have been diluted according to the instructions given in this manual 1:2, the concentration read from the standard curve must be multiplied by the dilution factor (x2). Calculation of samples with an O.D. exceeding 2.0 may result in incorrect, low monkey IL-10 levels. Such samples require further dilution of 1:4 - 1:8 or even higher with Assay Buffer in order to precisely quantitate the actual monkey IL-10 level.

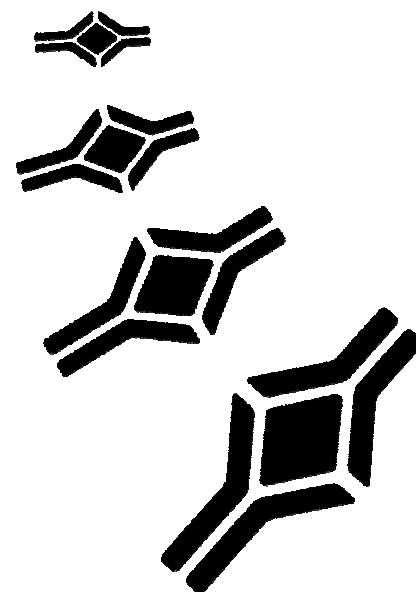

HEADQUARTERS: BioVendor Laboratorní medicína, a.s.	CTPark Modrice Evropska 873	664 42 Modrice CZECH REPUBLIC	Phone: +420-549-124-185 Fax: +420-549-211-460	E-mail: info@biovendor.com Web: www.biovendor.com
EUROPEAN UNION: BioVendor GmbH	Im Neuenheimer Feld 583	D-69120 Heidelberg GERMANY	Phone: +49-6221-433-9100 Fax: +49-6221-433-9111	E-mail: infoEU@biovendor.com
USA, CANADA AND MEXICO: BioVendor LLC	1463 Sand Hill Road Suite 227	Candler, NC 28715 USA	Phone: +1-828-670-7807 +1-800-404-7807 Fax: +1-828-670-7809	E-mail: infoUSA@biovendor.com
CHINA - Hong Kong Office: BioVendor Laboratories Ltd	Room 4008 Hong Kong Plaza, No.188	Connaught Road West Hong Kong, CHINA	Phone: +852-2803-0523 Fax: +852-2803-0525	E-mail: infoHK@biovendor.com
CHINA – Mainland Office: BioVendor Laboratories Ltd	Room 2405 YiYa Tower TianYu Garden, No.150	Lihe Zhong Road Guang Zhou, CHINA	Phone: +86-20-8706-3029 Fax: +86-20-8706-3016	E-mail: infoCN@biovendor.com